





# Profili Profiles

1:1

### M 9651

W = 904 gr/m

ŠTOK RAVNI-MALI  
FRAME SMALL FLAT

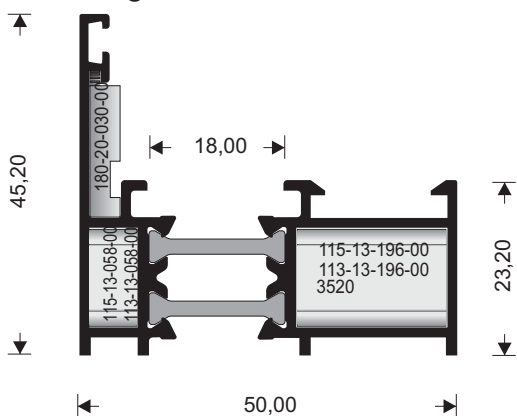

### BH 46

W = 1326 gr/m

ŠTOK RAVNI VELIKI  
FRAME LARGE FLAT

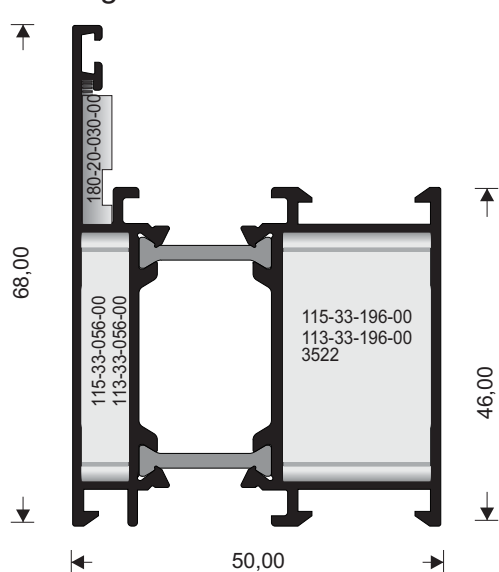

### M 9652

W = 1070 gr/m

ŠTOK RAVNI-SREDNJI  
FRAME MEDIUM FLAT

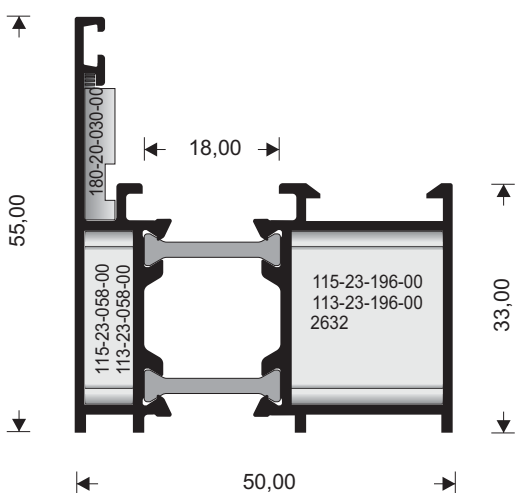

### M 9653

W = 1227 gr/m

ŠTOK ZAoblJENI-SREDNJI  
FRAME MEDIUM ROUND

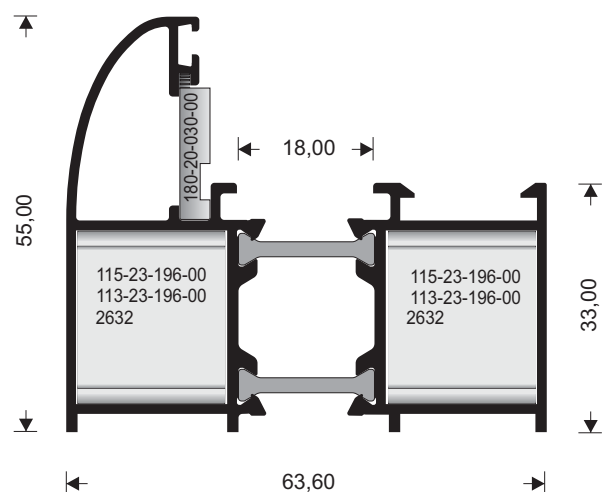

### M 9650

W = 1188 gr/m

ŠTOK RAVNI-SREDNJI  
FRAME MEDIUM FLAT

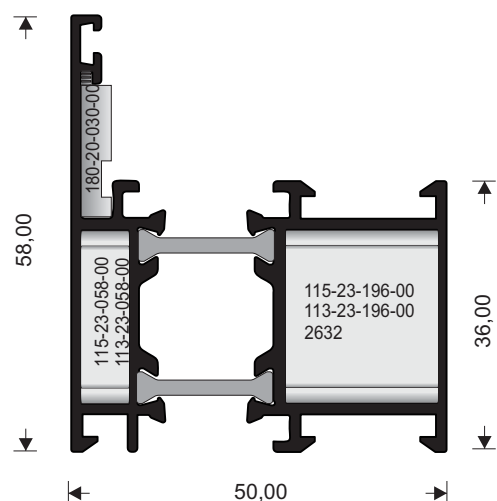

### BH 47

W=1,473 gr/m

ZAoblJENI ŠTOK  
FRAME ROUND

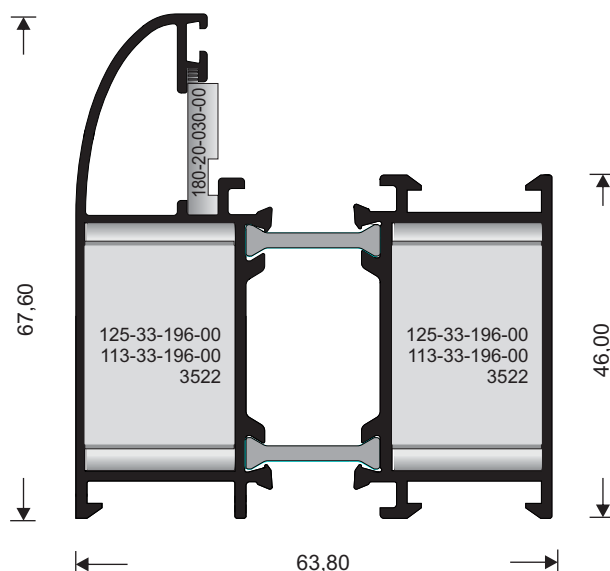

**M 9663**

KRILO RAVNO-SREDNJEMALO  
SASH MEDIUM FLAT

W = 1265 gr/m

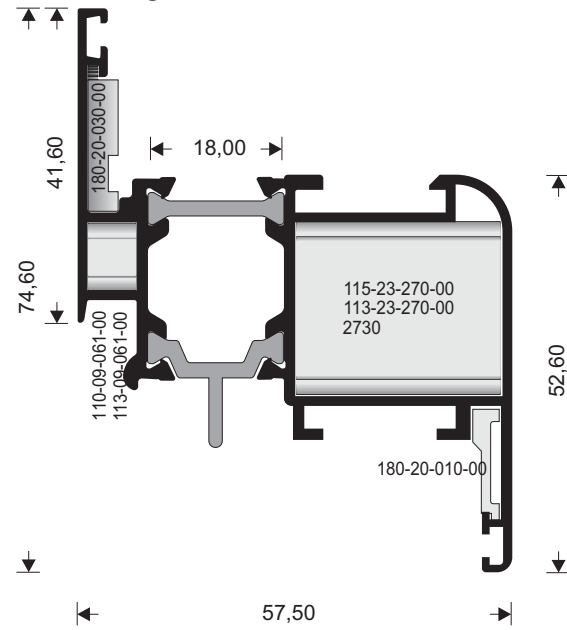

**M 9666**

KRILO ZAoblJENO-MALO  
SASH SMALL ROUND

W = 1224 gr/m

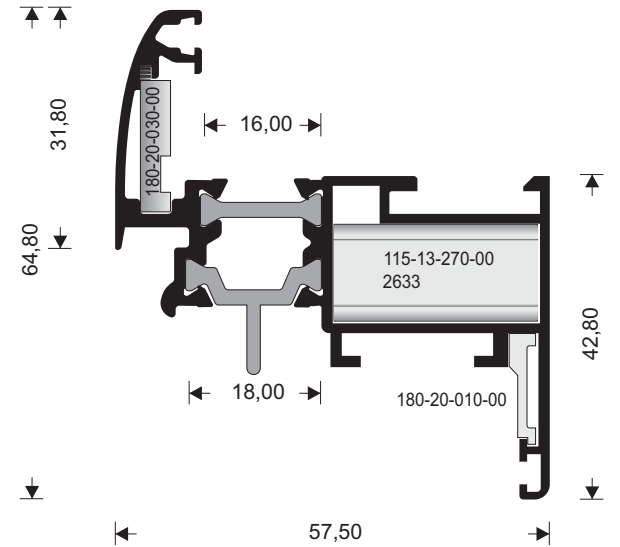

**M 9664**

KRILO RAVNO-VELIKO  
SASH LARGE FLAT

W = 1577 gr/m

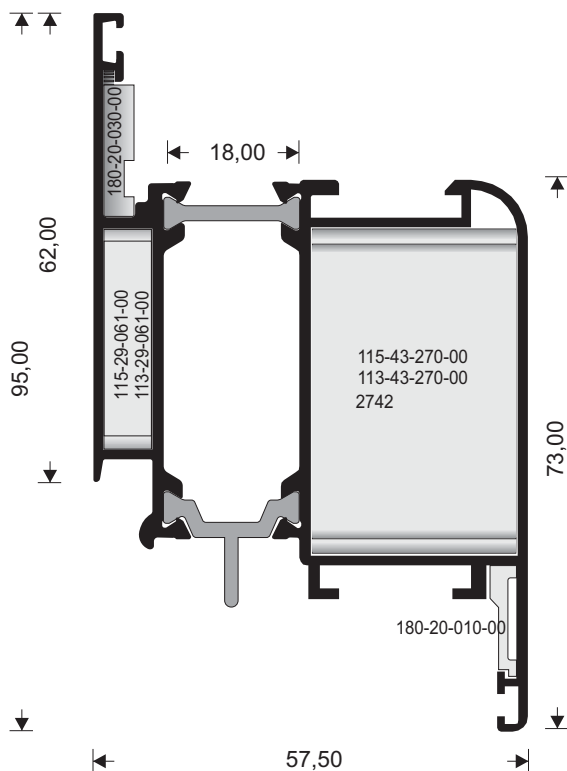

**M 9667**

ZAoblJENO KRILO-SREDNJE  
SASH MEDIUM ROUND

W = 1395 gr/m

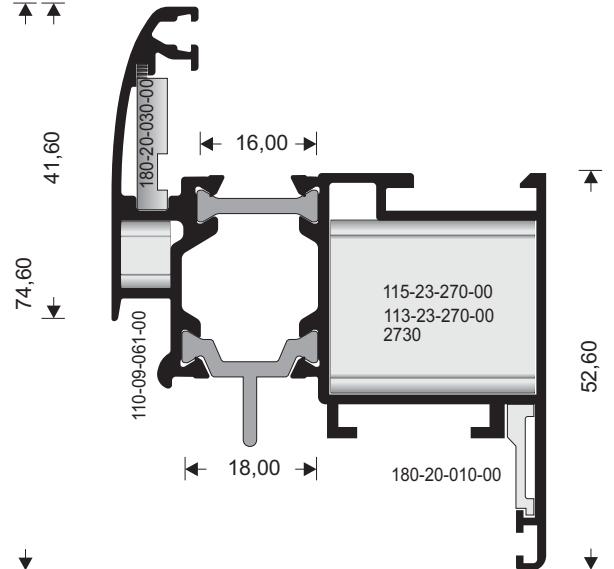

**M 9662**

KRILO RAVNO-MALO  
SASH SMALL FLAT

W = 1099 gr/m

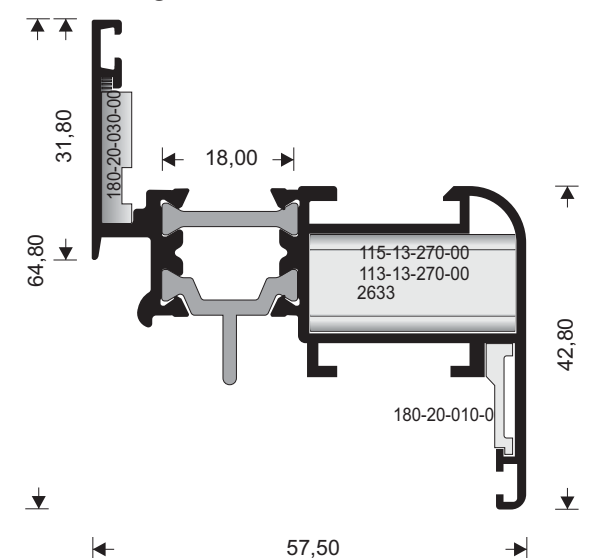

**M 9669**

KRILO VRATA ZA OBLJENO  
ZA OTVARANJE VANI  
SASH OPENING OUTSIDE  
ROUND LARGE

W = 1748 gr/m

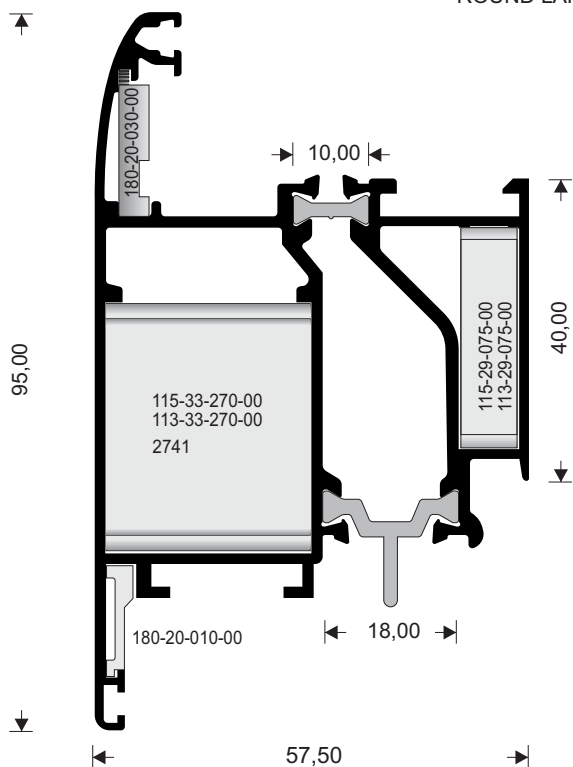

**M 9686**

KRILO SA KANALOM ZA PVC OKOV  
SASH WITH PVC CHANEL

W = 1384 gr/m

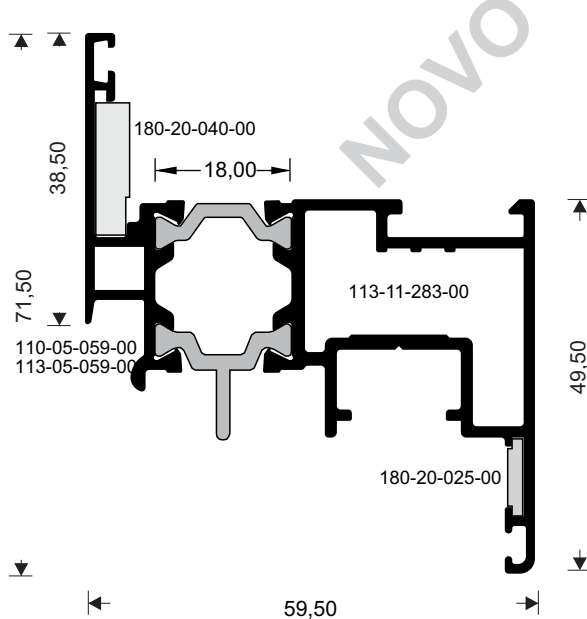

**M 9691**

PROFIL ZA PROMJENU SMJERA OTVARANJA  
SUPPLEMENTARY PROFIL  
FOR OPENING OUTSIDE

W = 1033 gr/m

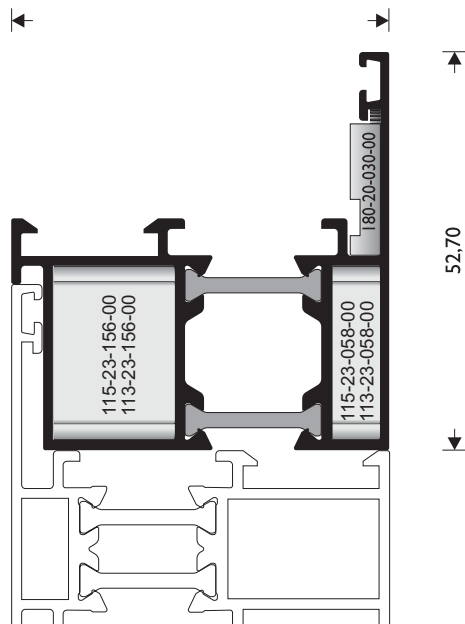

**M 9668**

KRILO ZA OBLJENO-VELIKO  
SASH LARGE ROUND

W = 1695 gr/m

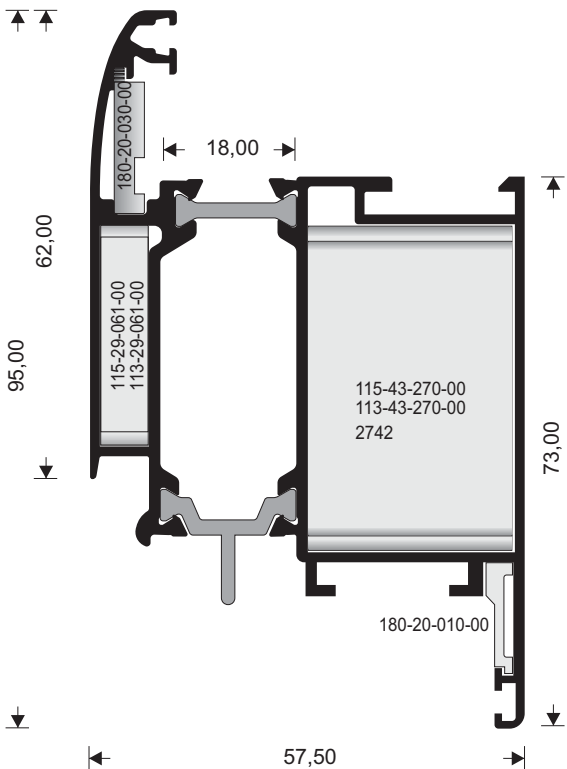

**M 9690**

W = 1426 gr/m

"T" PREČKA

"T" PROFILE

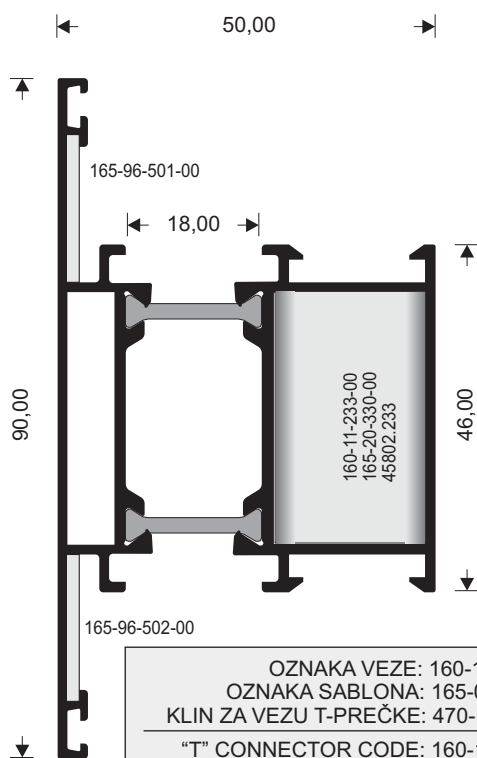

OZNAKA VEZE: 160-11-233-00  
OZNAKA SABLONA: 165-00-001-00  
KLIN ZA VEZU T-PREČKE: 470-11-835-00  
"T" CONNECTOR CODE: 160-11-233-00  
DRILLING GUIDE CODE: 165-00-001-00  
NAIL FOR T -PROFILE: 470-11-835-00

OZNAKA LIVENE VEZE: 165-20-330-00  
"T" CONNECTOR CODE: 165-20-330-00

**M 9693**

W = 2452 gr/m

T-PREČKA

"T" PROFILE

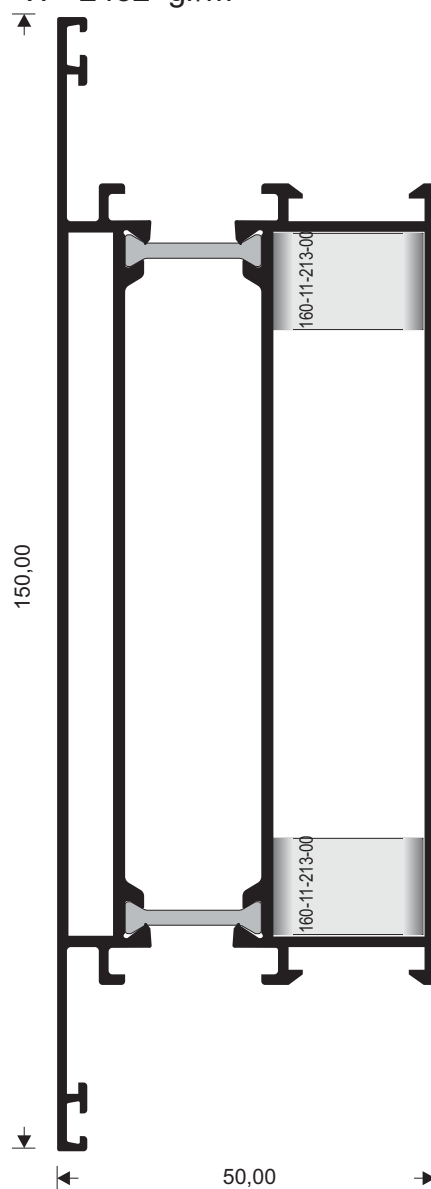

**M 9656**

W = 1870 gr/m

OJAČANA "T" PREČKA

"T" PROFILE

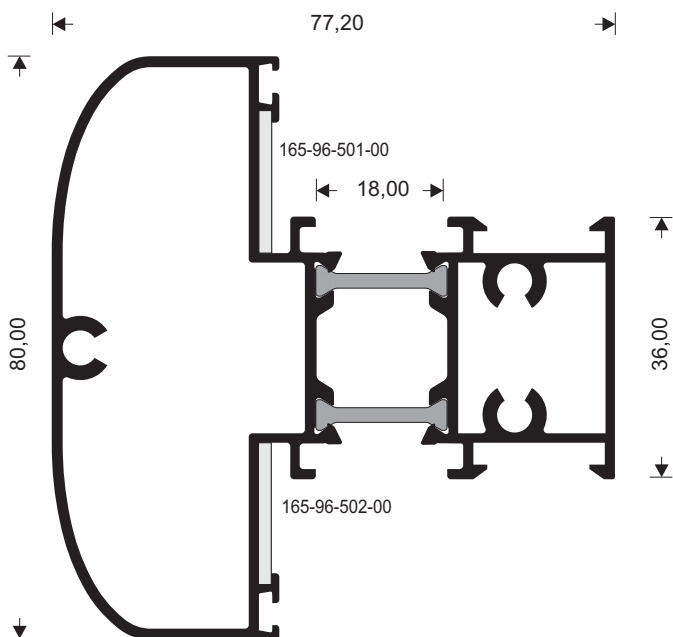

**M 9659**

W = 1304 gr/m

"T" PREČKA  
"T" PROFILE

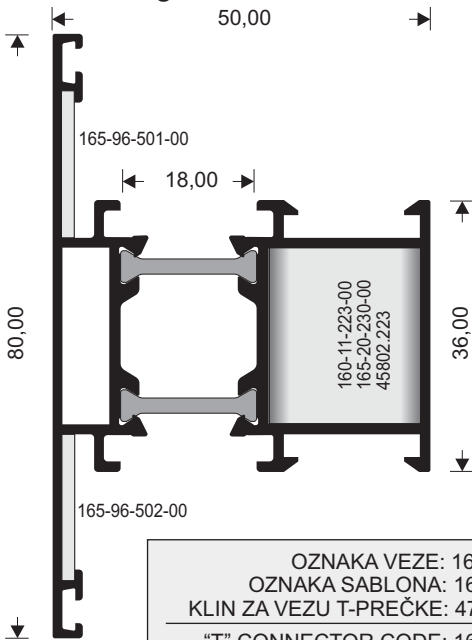

OZNAKA VEZE: 160-11-223-00  
OZNAKA SABLONA: 165-00-001-00  
KLIN ZA VEZU T-PREČKE: 470-11-835-00  
"T" CONNECTOR CODE: 160-11-223-00  
DRILLING GUIDE CODE: 165-00-001-00  
NAIL FOR T -PROFILE: 470-11-835-00

OZNAKA LIVENE VEZE: 165-20-230-00  
"T" CONNECTOR CODE: 165-20-230-00

**2266**

W = 1569 gr/m

OJAČANJE ZA M9690  
SUPPLEMENTARY PROFILE 9690

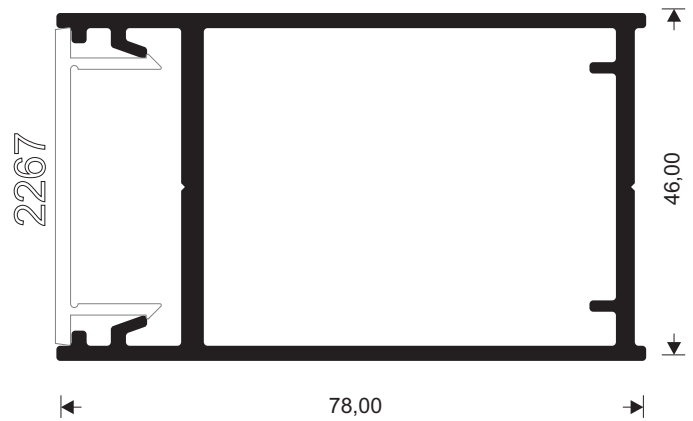

**2267**

W = 318 gr/m

POKLOPAC ZA 2266  
CAP FOR 2266

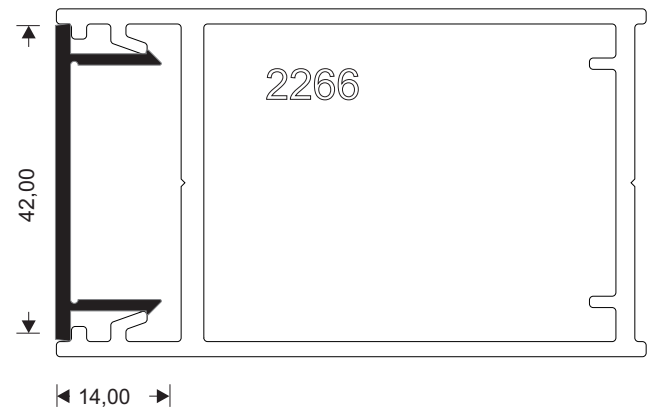

**M 11178**

W = 1285 gr/m

PROFIL ZA PODEŠAVAJUĆI UGAO  
CIRCULAR COLUMN  
FOR VARIABLE ANGLES

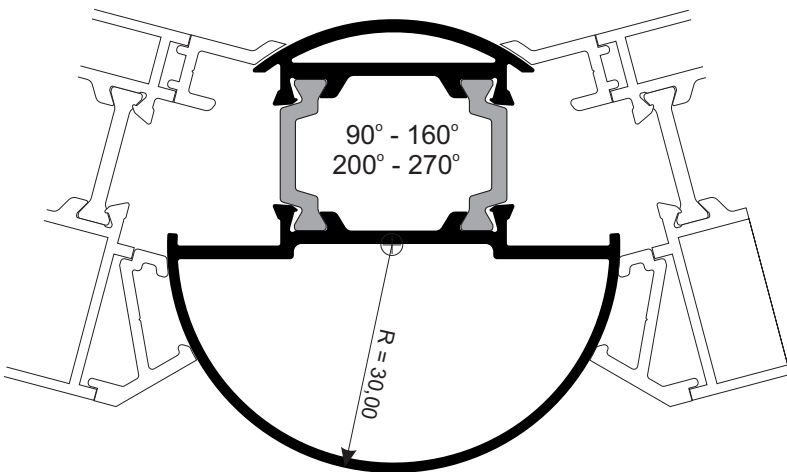

**M 9671**

W = 111 gr/m

LAJSNA ZA PROFIL ZA PODEŠAVAJUĆI UGAO  
ADJOINING PROFILE  
FOR CIRCULAR COLUMN

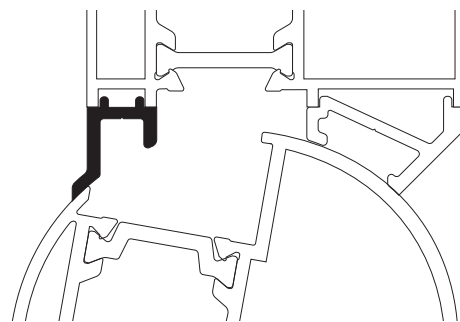

**M 9670**

W = 177 gr/m

LAJSNA ZA PROFIL ZA PODEŠAVAJUĆI UGAO  
ADJOINING PROFILE  
FOR CIRCULAR COLUMN

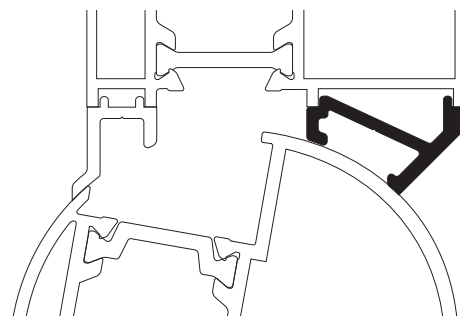



**M 9665**

W = 1185 gr/m

SREDNJA PRECKA RAVNA  
ADJOINING PROFILE FLAT

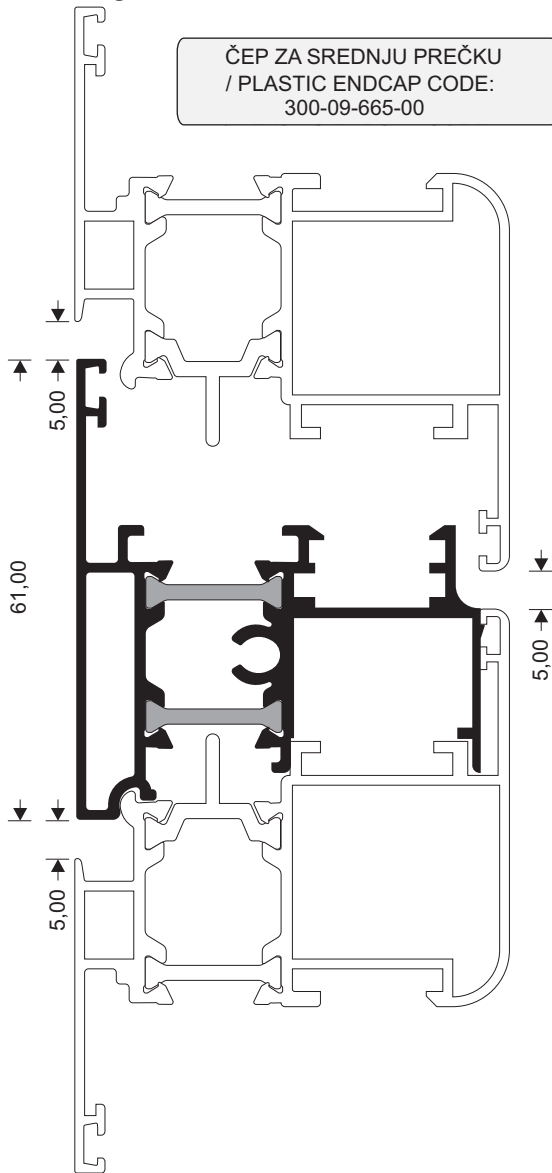

**M 9685**

W = 1233 gr/m

SREDNJA PRECKA ZAOBLJENA  
ADJOINING PROFILE ROUND

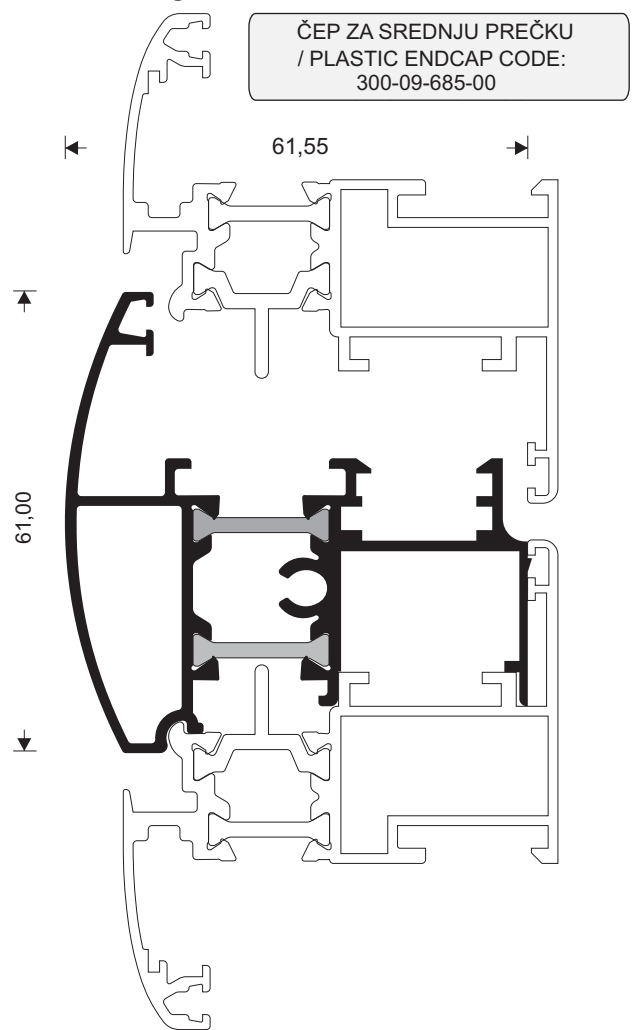

**M 11218**

W = 345 gr/m

DODATNI PROFIL ZA PRAG  
SUPPLEMENTARY PROFILE  
FOR KICK PLATE

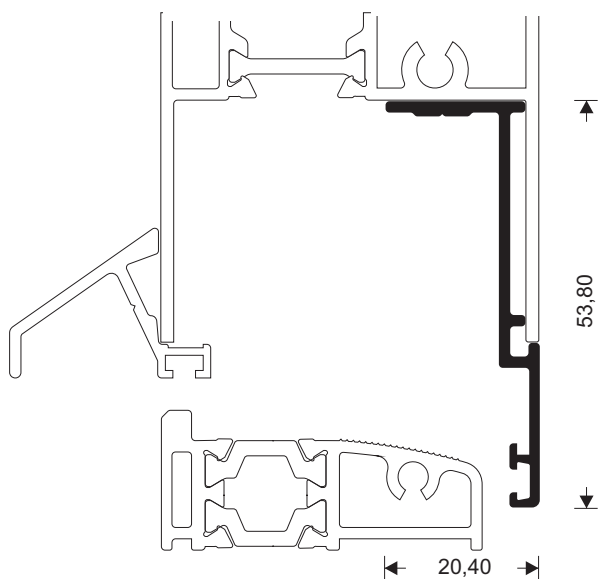

**M 9672**

W = 726 gr/m

PRAG  
THRESHOLD

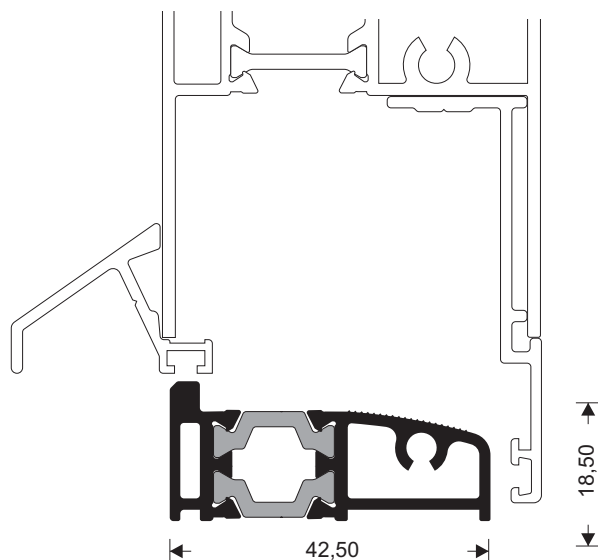

OZNAKA PVC ČEPOVA / PLASTIC ENDCAP CODE: 310-09-672-00

**M 11226**

W = 227 gr/m

OKAPNICA  
WATER CAP

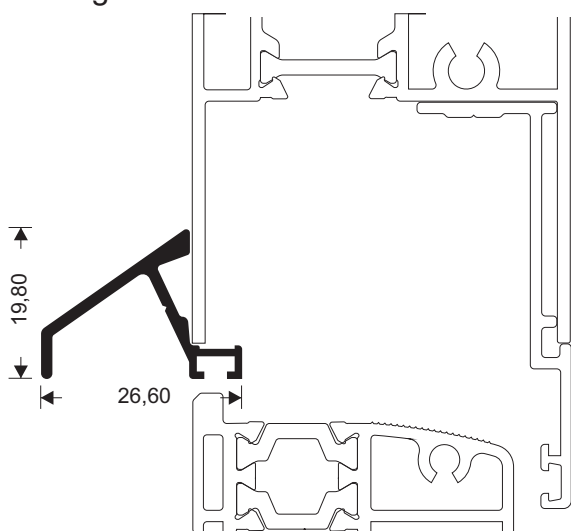

OZNAKA PVC ČEPOVA / PLASTIC ENDCAP CODE: 310-11-226-00

**M 11116**

W = 183 gr/m

OKAPNICA  
WATER CAP

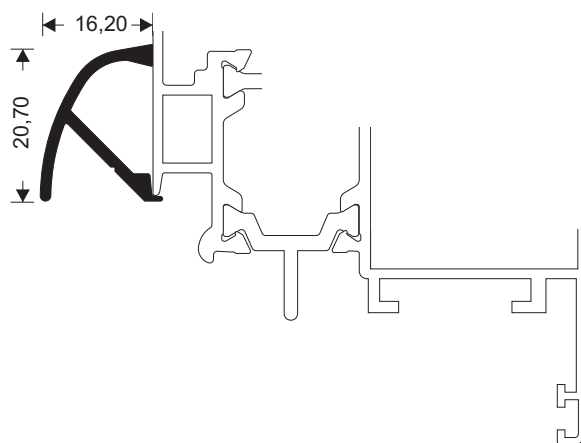

OZNAKA PVC ČEPOVA / PLASTIC ENDCAP CODE: 310-11-116-00

**M 9317**

W = 180 gr/m

OKAPNICA  
WATER CAP

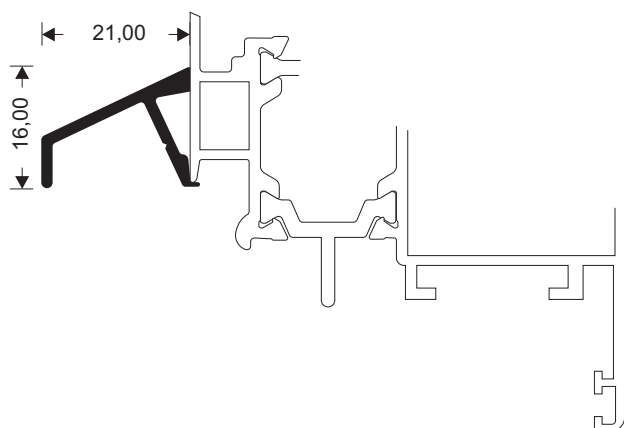

OZNAKA PVC ČEPOVA / PLASTIC ENDCAP CODE: 310-09-317-00

**M 9316**

W=136 gr/m

POTISNA LETVA  
ROD

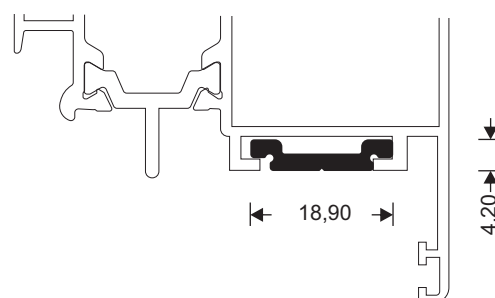

**M 9661**

W = 2731 gr/m

PARAPET  
KICKPLATE

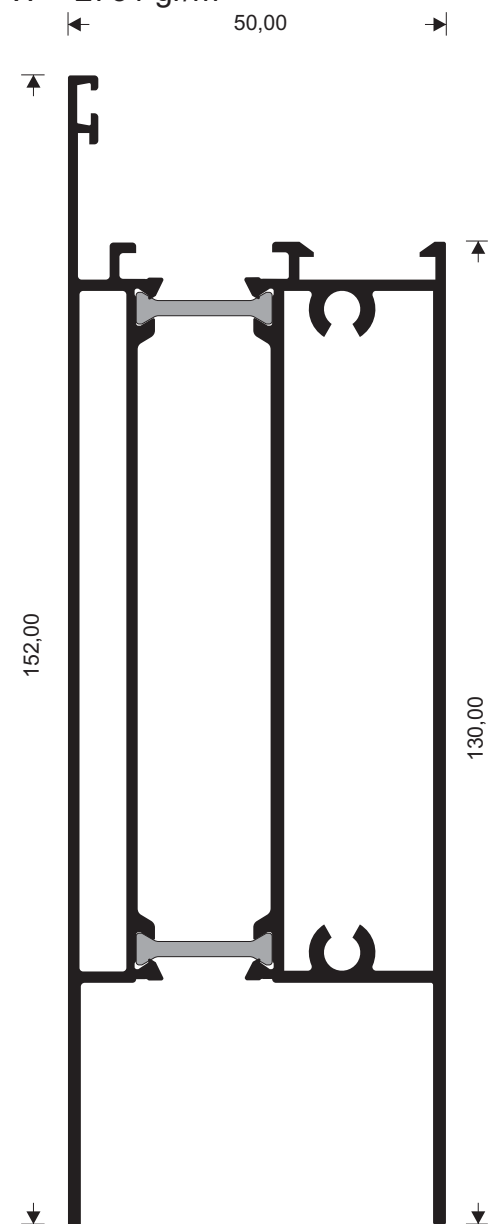

**M 11211**

W=268 gr/m

PROFIL ZA DNO VRATA  
SUPPLEMENTARY PROFILE FOR DOORS

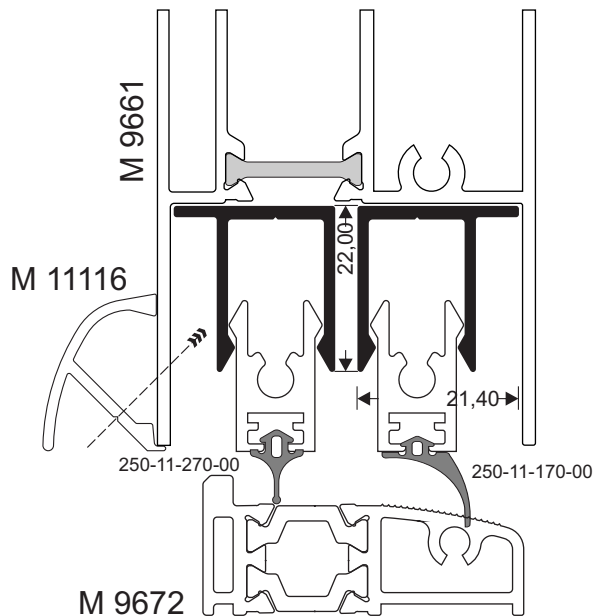

**M 11210**

W=283 gr/m

PROFIL ZA DNO VRATA NOSAČ GUME  
SUPPLEMENTARY PROFILE FOR DOORS

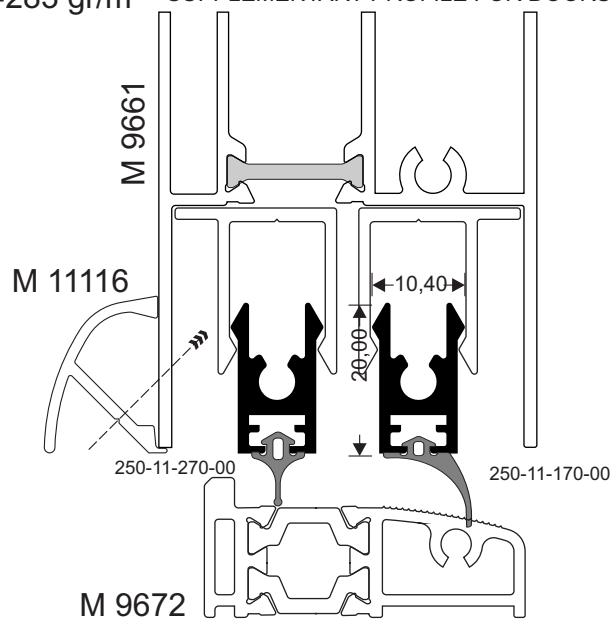

OZNAKA POKLOPCA / ENDCAP CODE: 310-11-210-00

**M 9681**

W=890 gr/m

DODATAK ZA DNO VRATA  
SUPPLEMENTARY PROFILE  
FOR DOORS

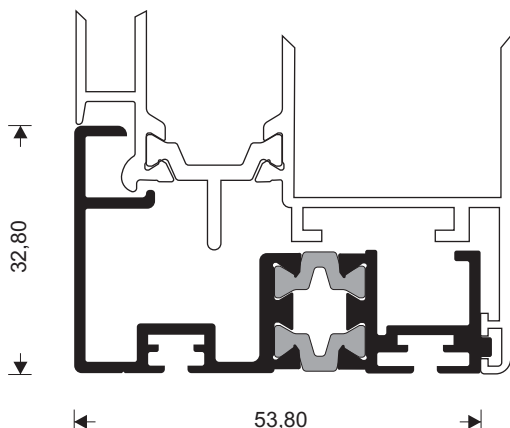

OZNAKA POKLOPCA / ENDCAP CODE: 310-09-681-00

**M 9673**

W = 802 gr/m

PROFIL ZA DNO VRATA  
END CAP FOR DOORS

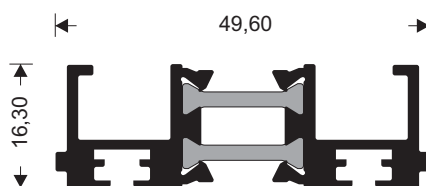

OZNAKA POKLOPCA / ENDCAP CODE: 310-09-673-00

**M 9684**

W = 1305 gr/m

UGAO 90 STEPENI  
CORNER 90 DEGREE

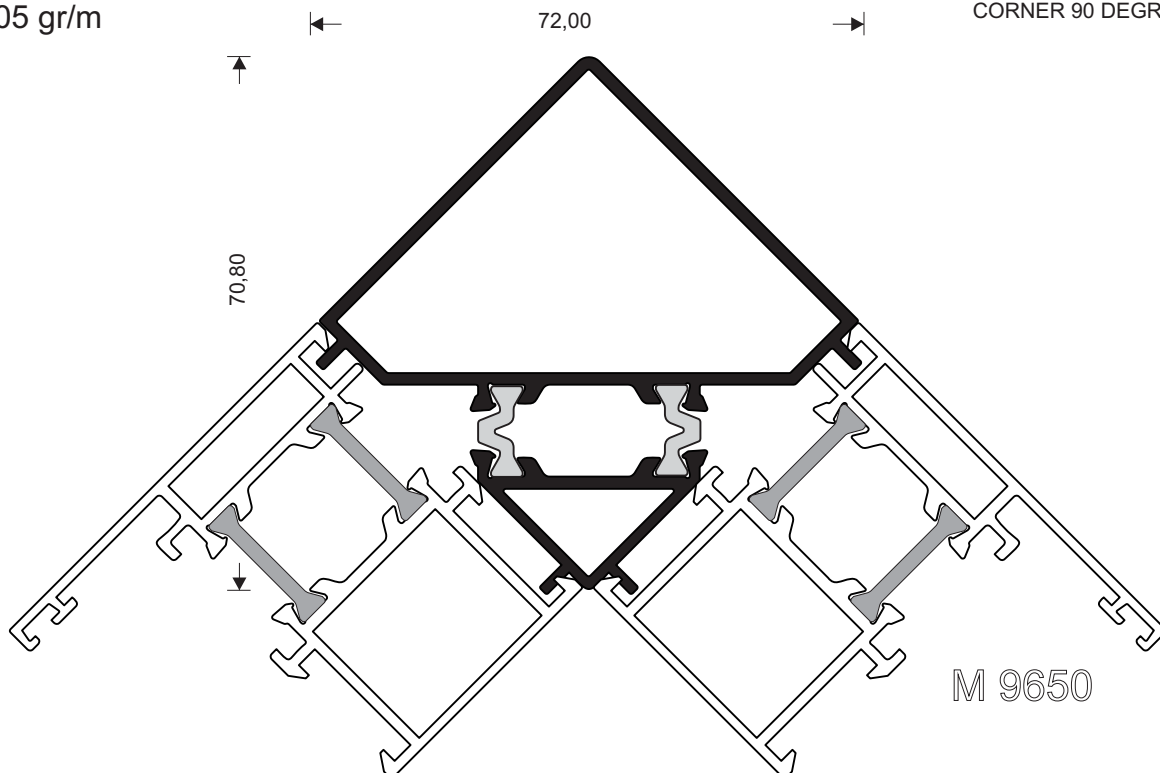

**M 9419**

W=397 gr/m

DEKORATIVNI PROFIL  
DECORATIVE ARMATURE

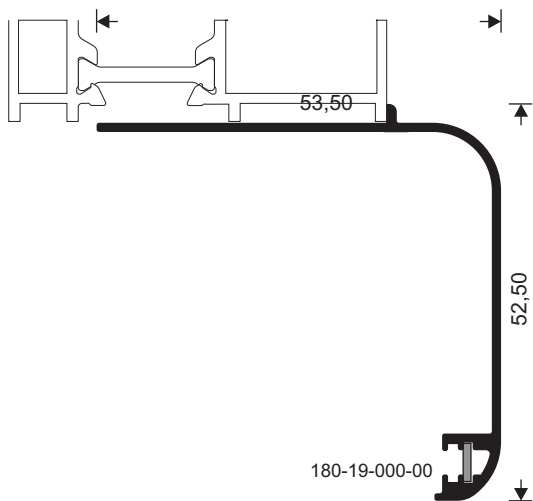

**M 11118**

W = 324 gr/m

PROFIL DODATAK ŠTOKA  
SUPPLEMENTARY PROFILE

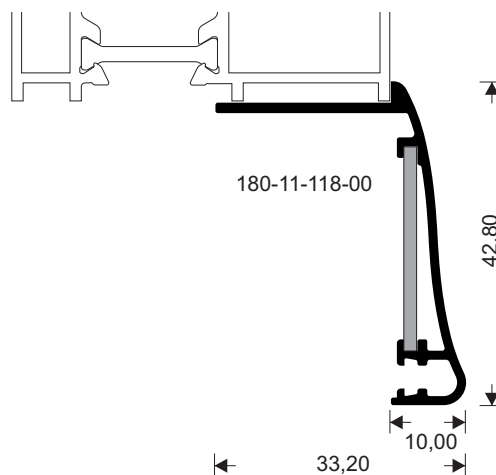

**M 11451**

W = 307 gr/m

LAJSNA ZA STAKLO  
GLAZING BEAD

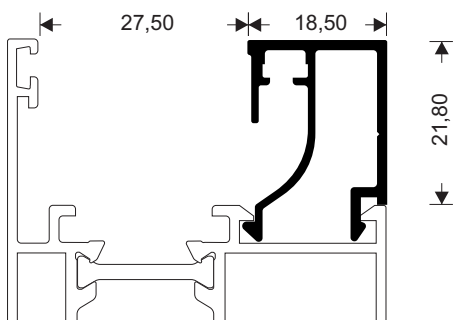

DEBLJINA ISPUNE / GLAZING THICKNESS: 20mm

**M 11461**

W=286 gr/m

LAJSNA ZA STAKLO  
GLAZING BEAD

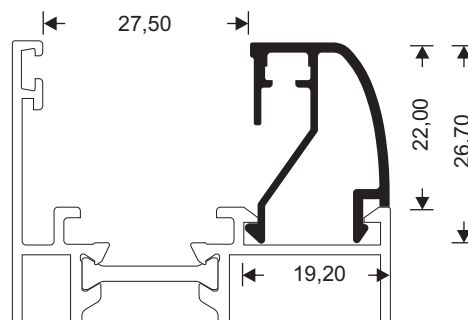

DEBLJINA ISPUNE / GLAZING THICKNESS: 20mm

**M 11452**

W=313 gr/m

LAJSNA ZA STAKLO  
GLAZING BEAD

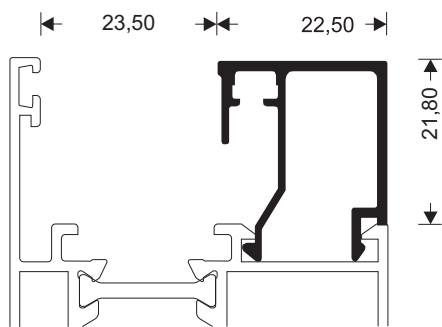

DEBLJINA ISPUNE / GLAZING TICKNESS: 16mm

**M 11462**

W = 297 gr/m

LAJSNA ZA STAKLO  
GLAZING BEAD

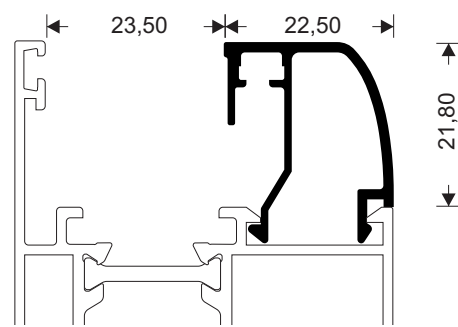

DEBLJINA ISPUNE / GLAZING TICKNESS: 16mm

**M 11453**

W=328 gr/m

LAJSNA ZA STAKLO  
GLAZING BEAD

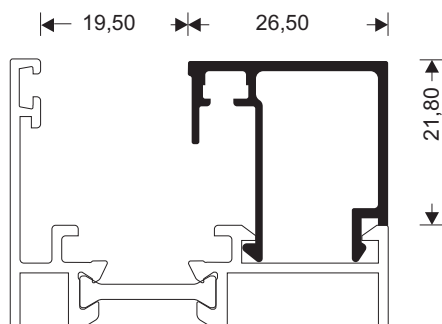

DEBLJINA ISPUNE / GLAZING TICKNESS: 12mm

**M 11463**

W=311 gr/m

LAJSNA ZA STAKLO  
GLAZING BEAD

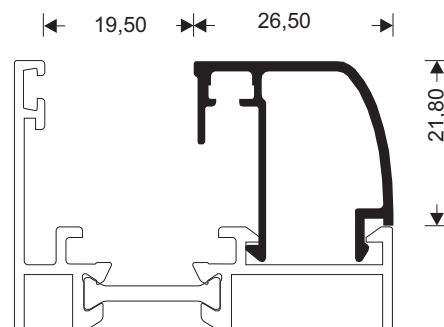

DEBLJINA ISPUNE / GLAZING TICKNESS: 12mm

**M 11454**

W=350 gr/m

LAJSNA ZA STAKLO  
GLAZING BEAD

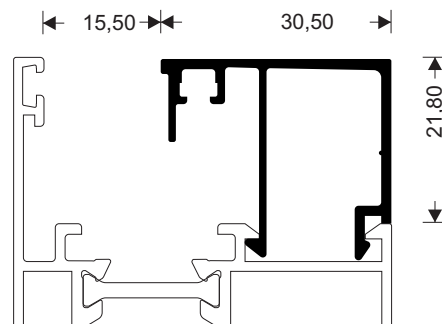

DEBLJINA ISPUNE / GLAZING TICKNESS: 8mm

**M 11464**

W=332 gr/m

LAJSNA ZA STAKLO  
GLAZING BEAD

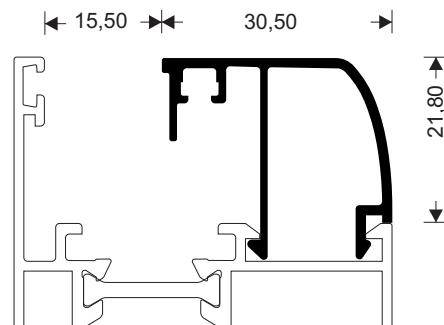

DEBLJINA ISPUNE / GLAZING TICKNESS: 8mm

**M 9312**

W=241 gr/m

LAJSNA ZA STAKLO  
GLAZING BEAD

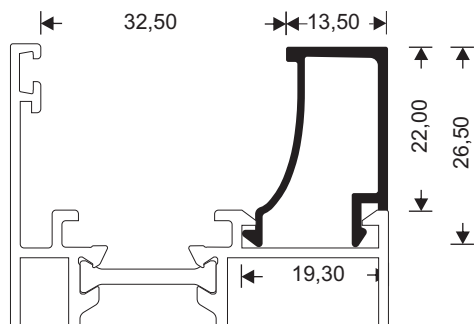

DEBLJINA ISPUNE / GLAZING TICKNESS: 24mm

**M 9565**

W=254 gr/m

LAJSNA ZA STAKLO  
GLAZING BEAD

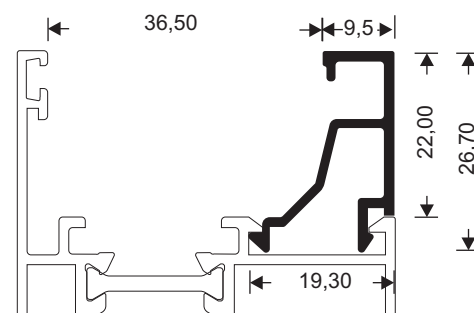

DEBLJINA ISPUNE / GLAZING TICKNESS: 28mm



# Presjeci Sections

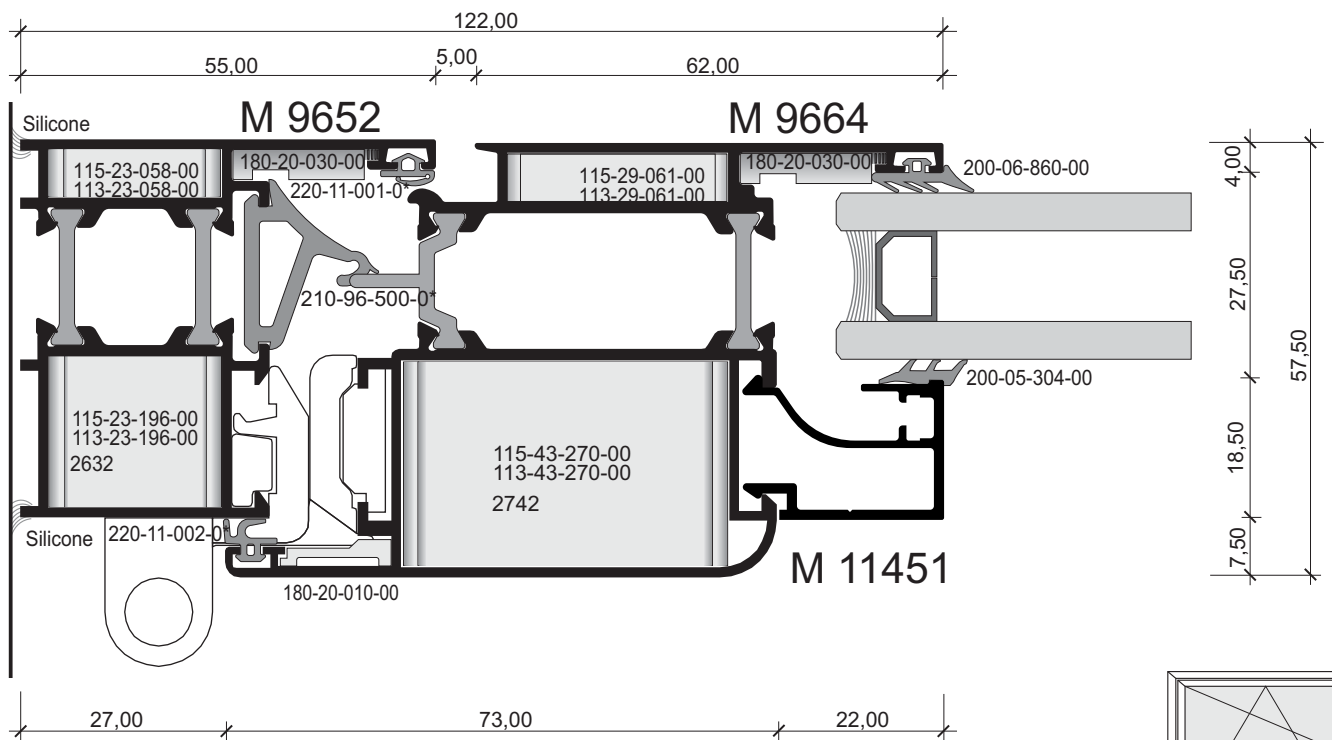
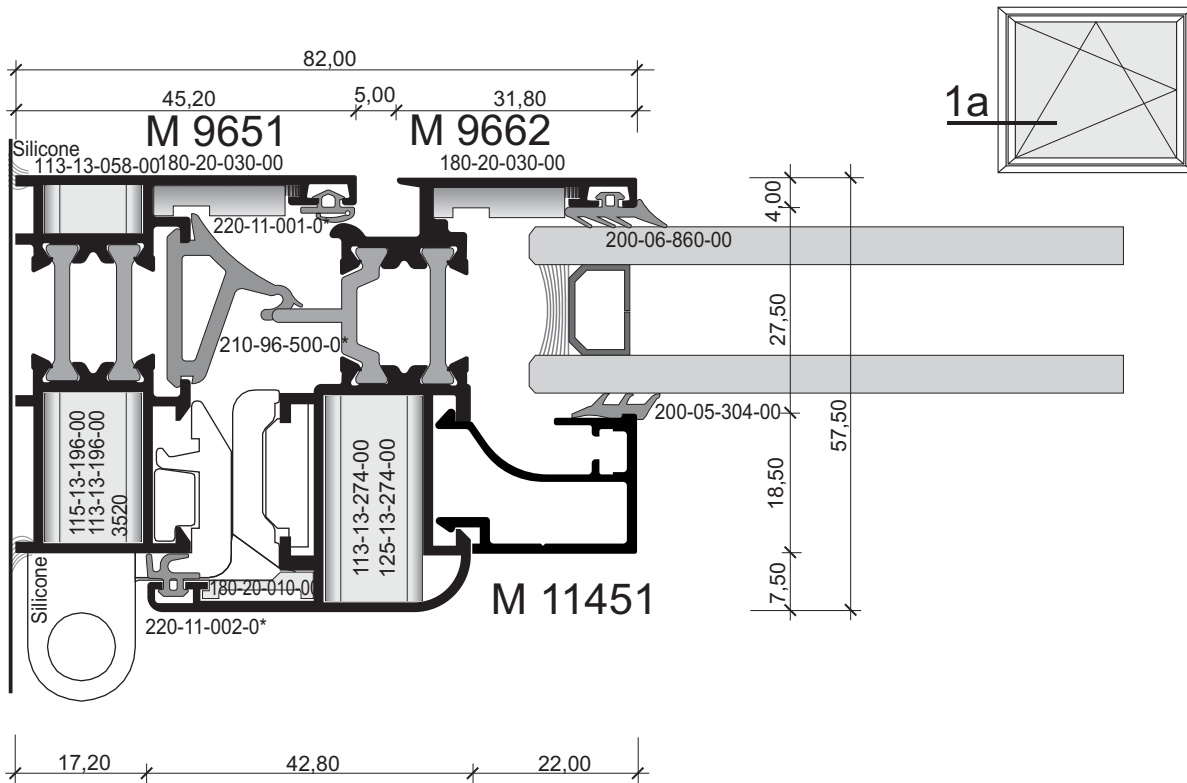



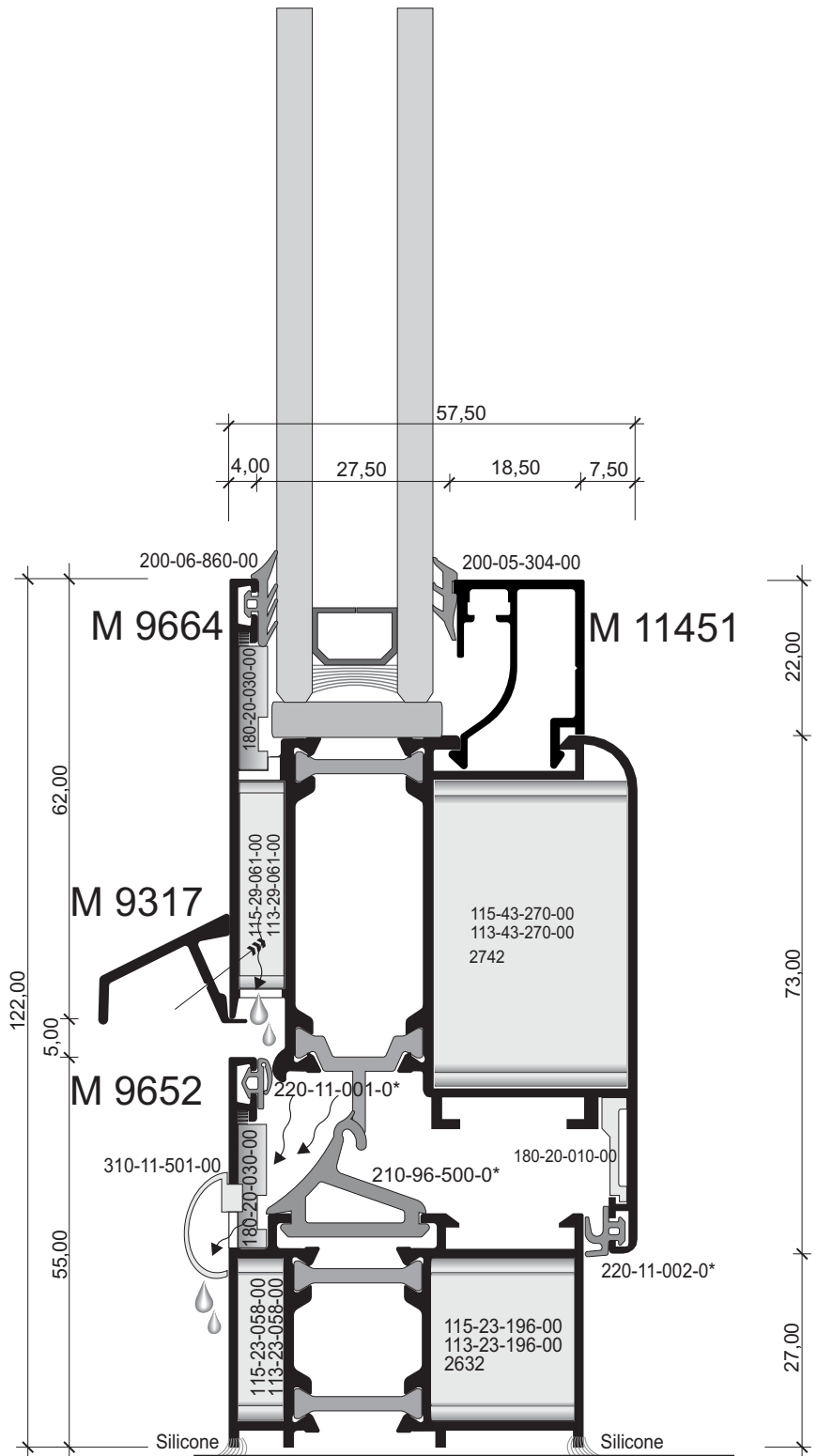
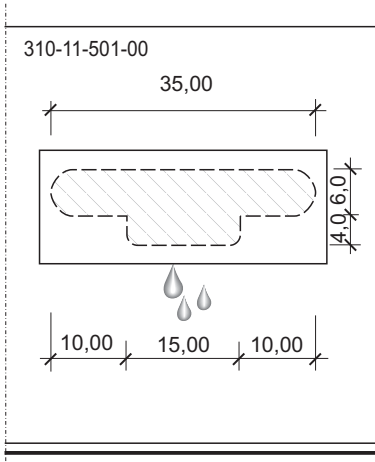
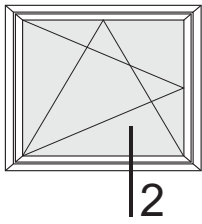

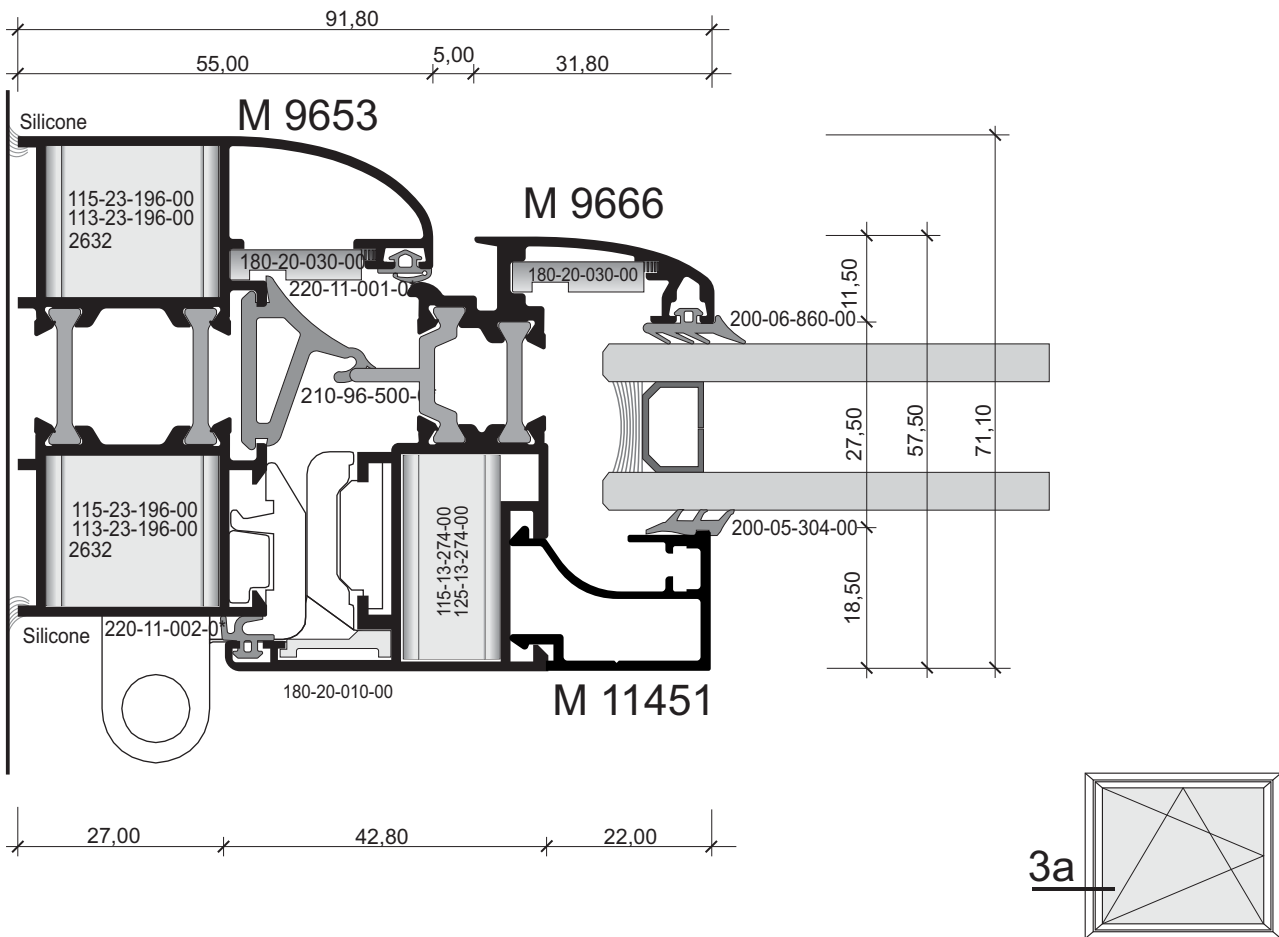
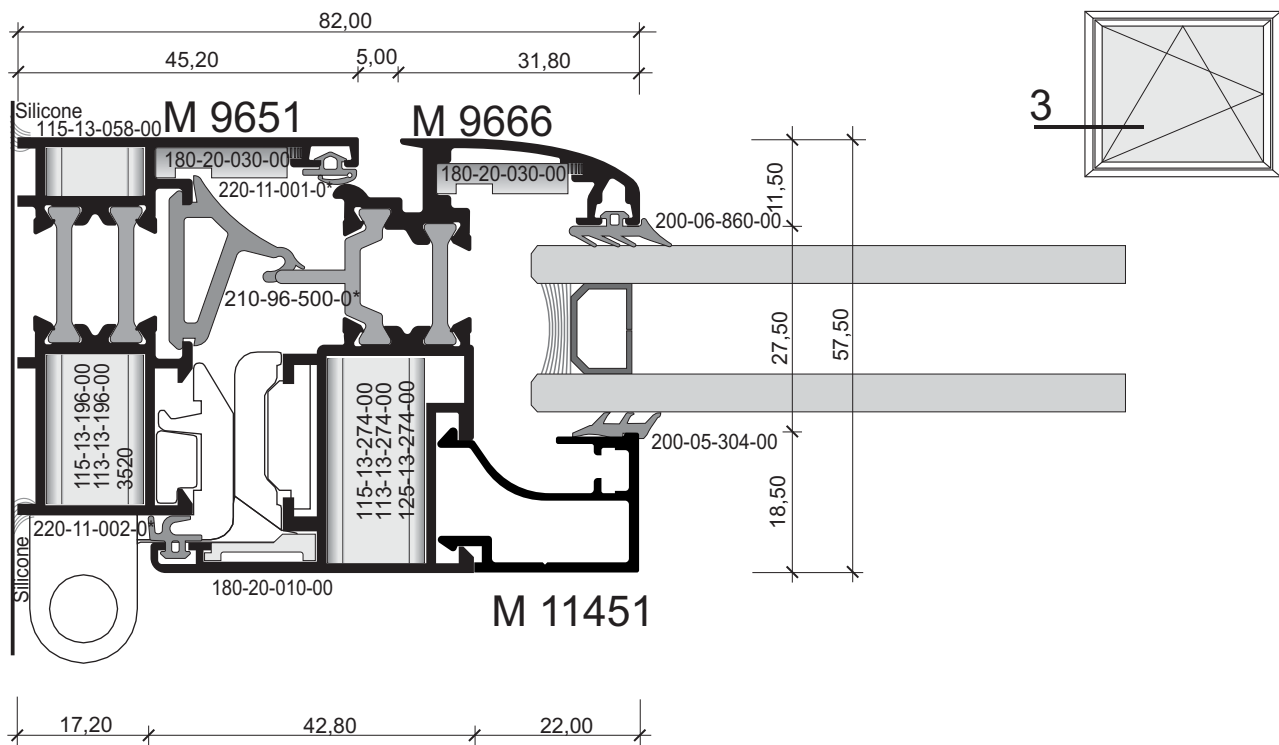

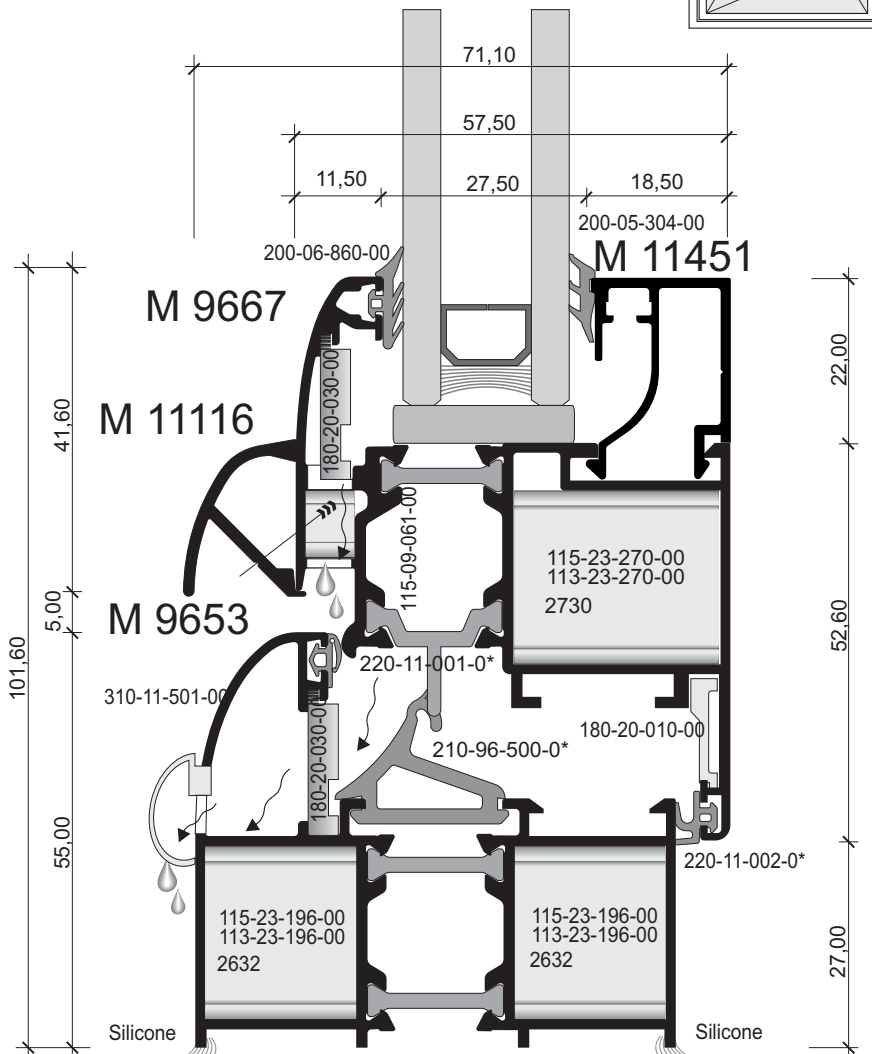
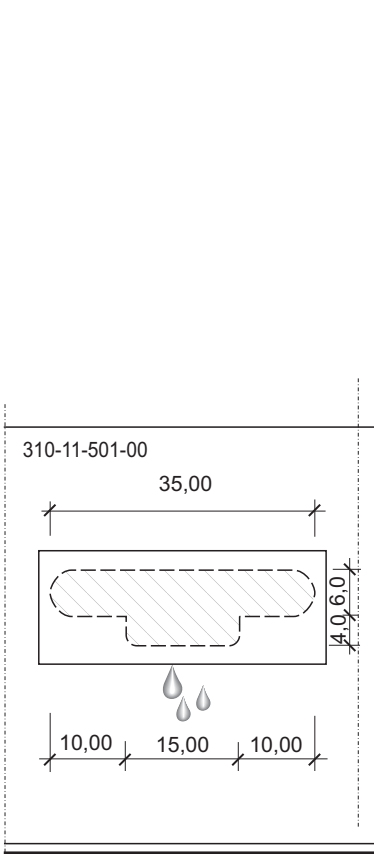
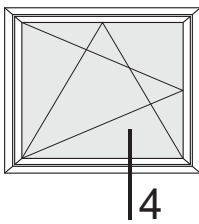
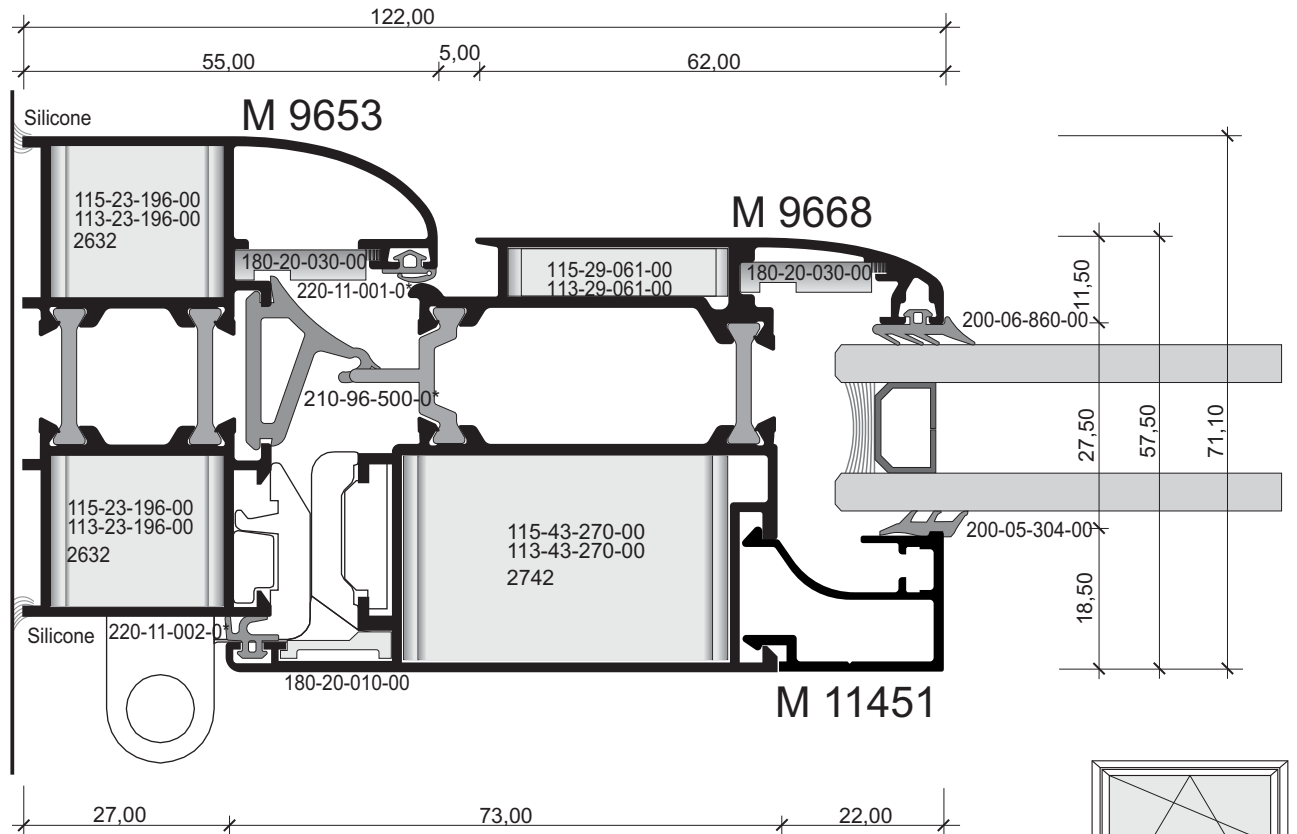

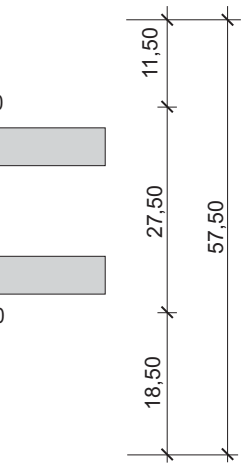
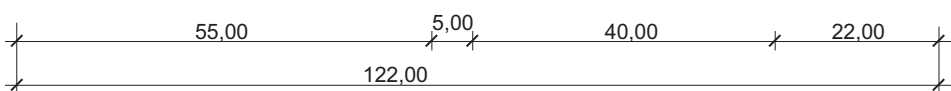
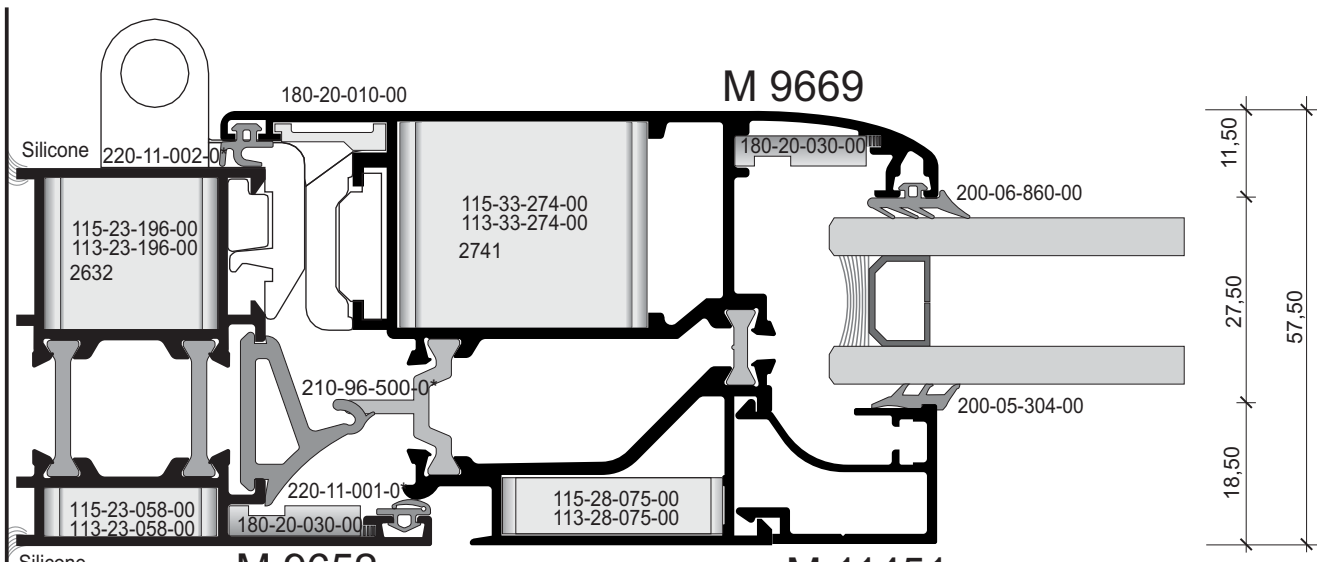
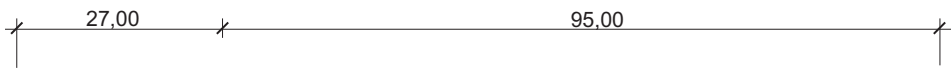
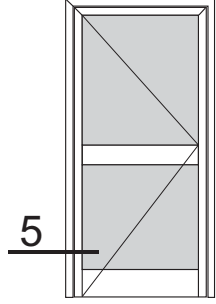
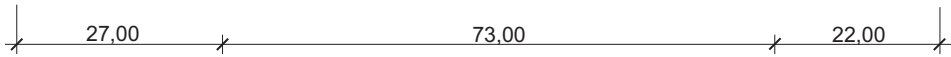
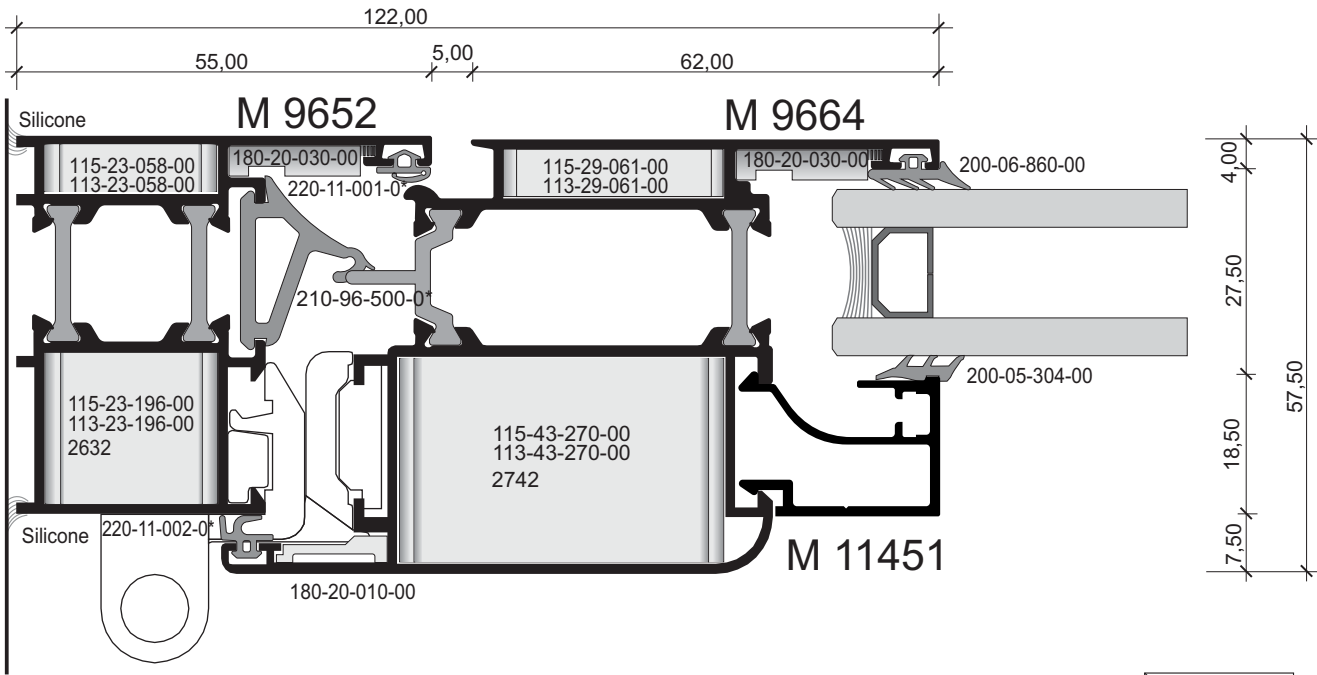

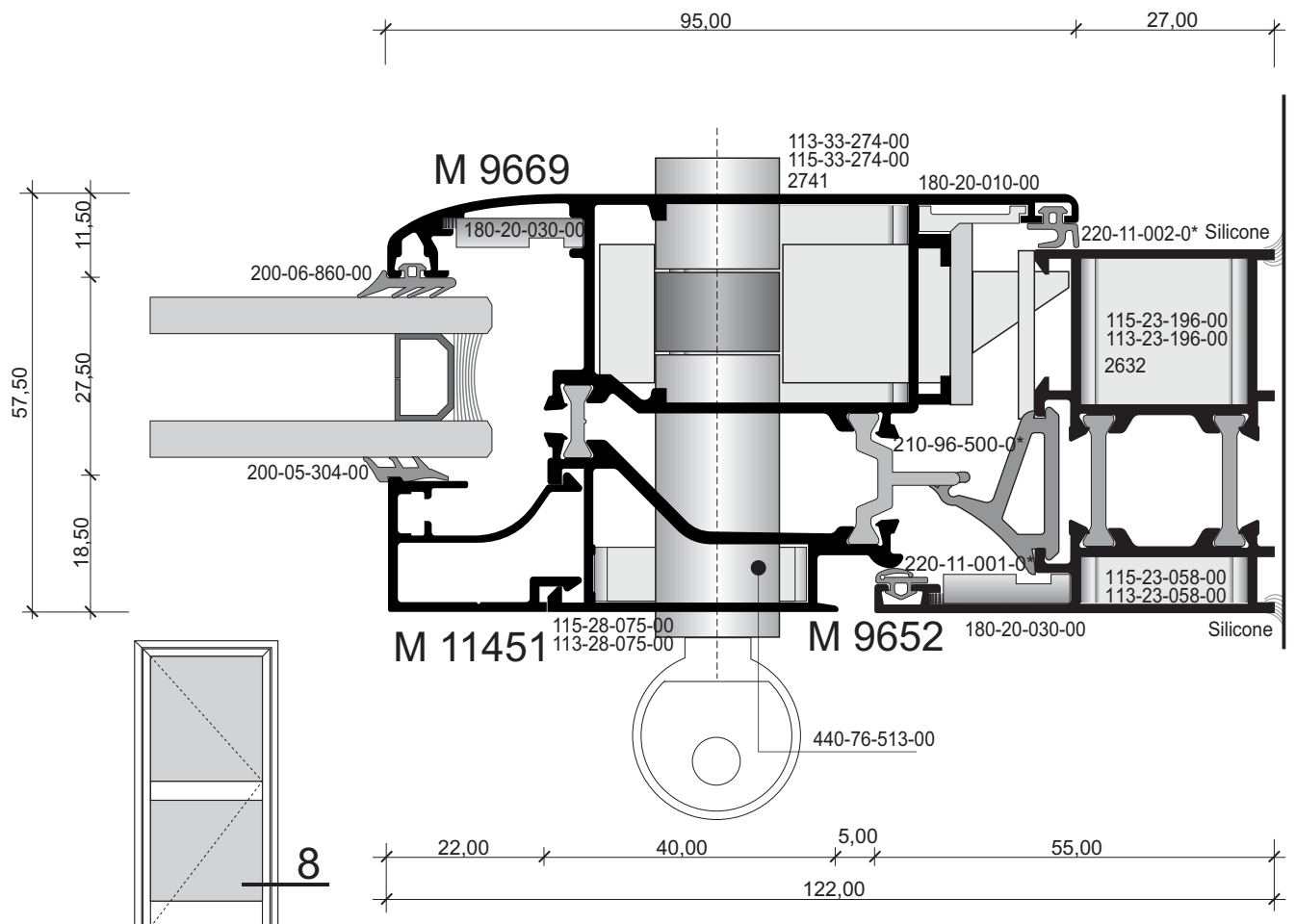
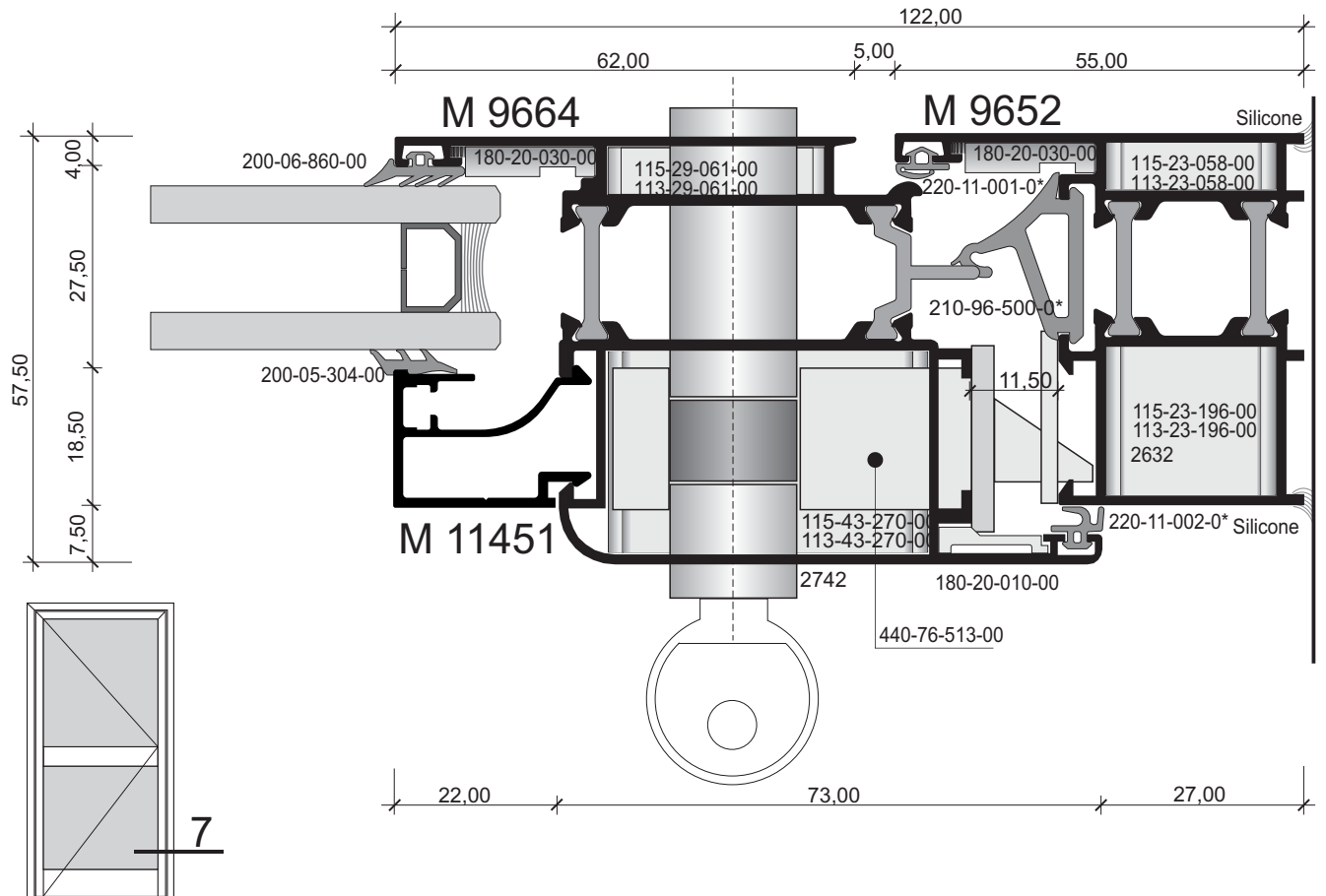

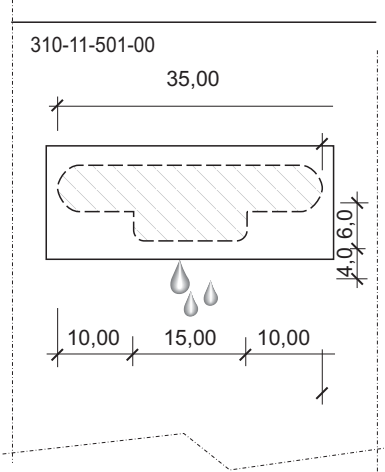
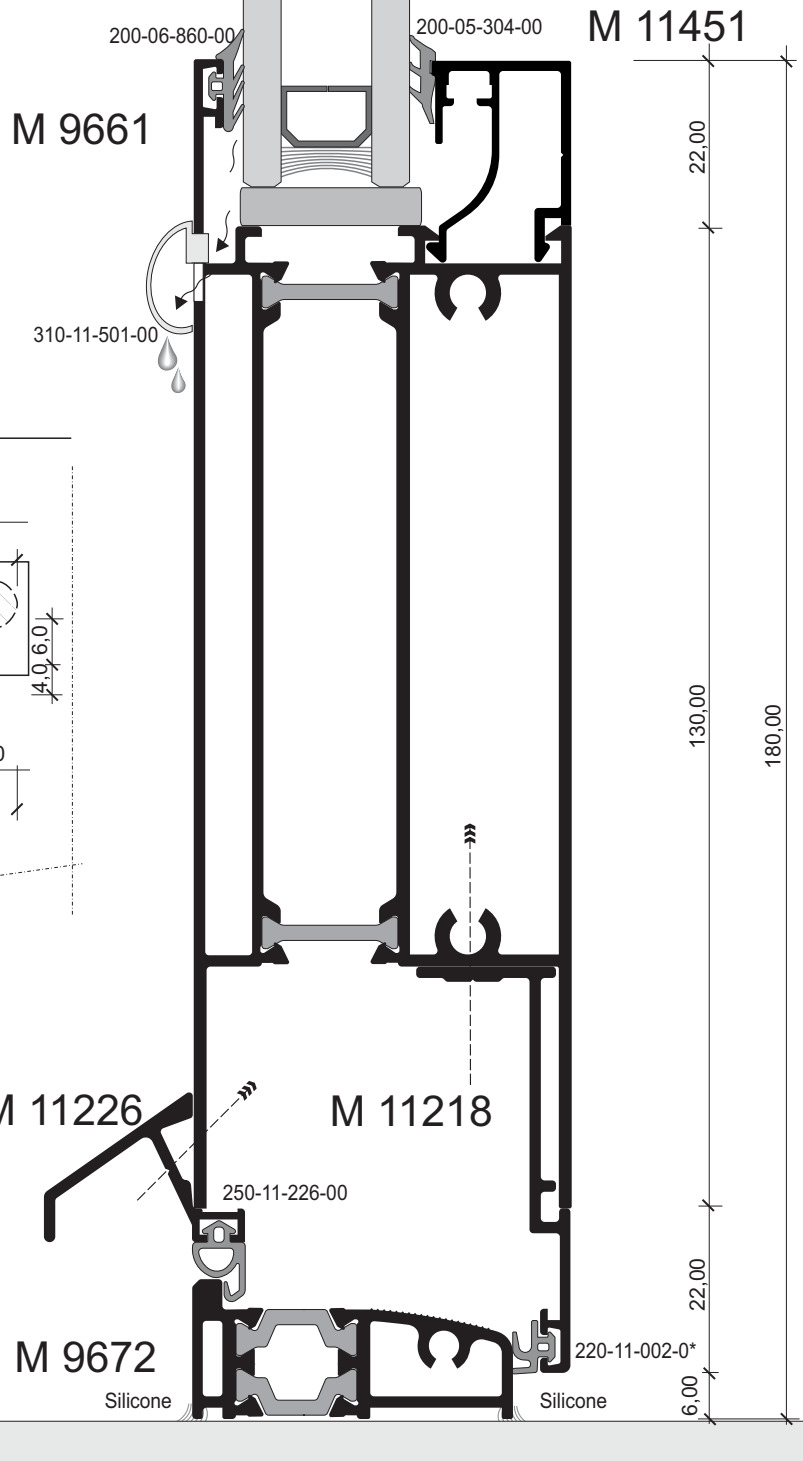
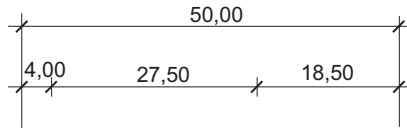
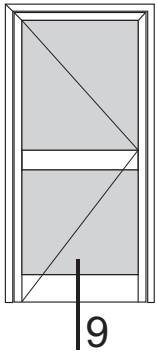

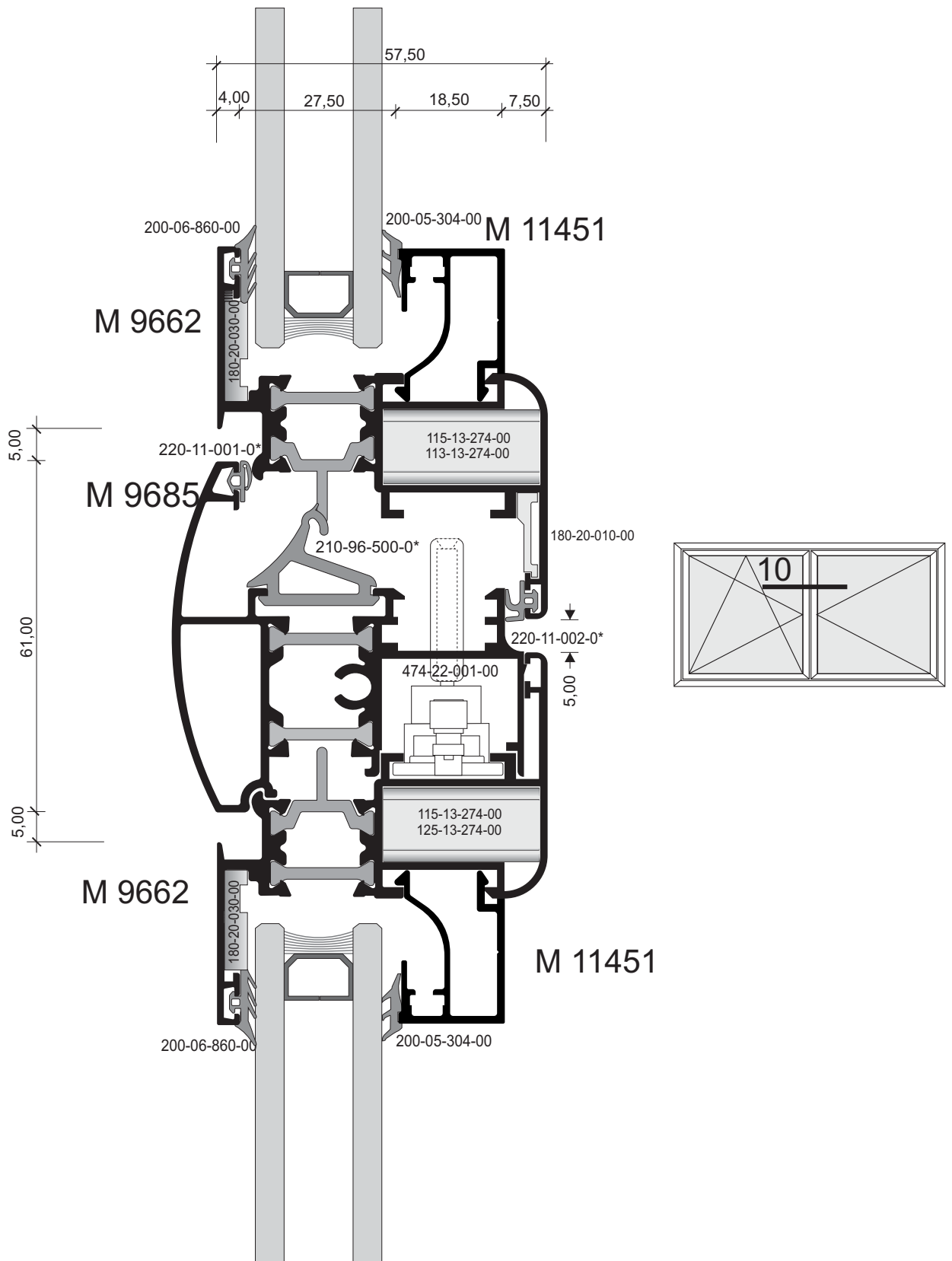





# Analiza sječenja Cutting Analysis

JEDNOKRILNI PROZOR/ OKRETNO-NAGIBNI  
SINGLE LEAF CASEMENT/ TILT-N-TURN WINDOW

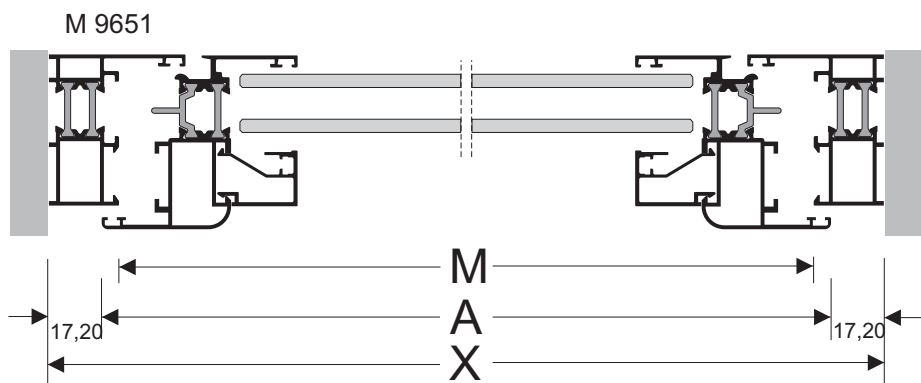

VISINA ILI ŠIRINA KRILA  
(HEIGHT OR WIDTH OF SASH) ili (or)  
 $A = Y - 34,4\text{mm}$   
 $A = M + 12\text{ mm}$

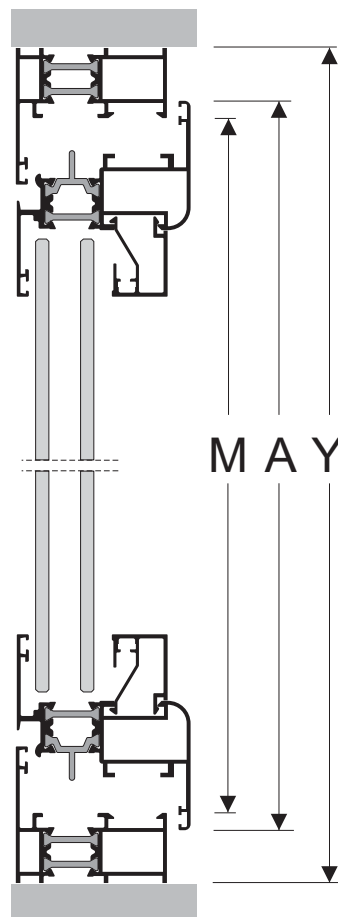
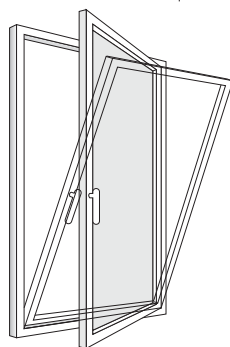

DVOKRILNI PROZOR/ OKRETNO-NAGIBNI  
DOUBLE LEAF CASEMENT/ TILT-N-TURN WINDOW

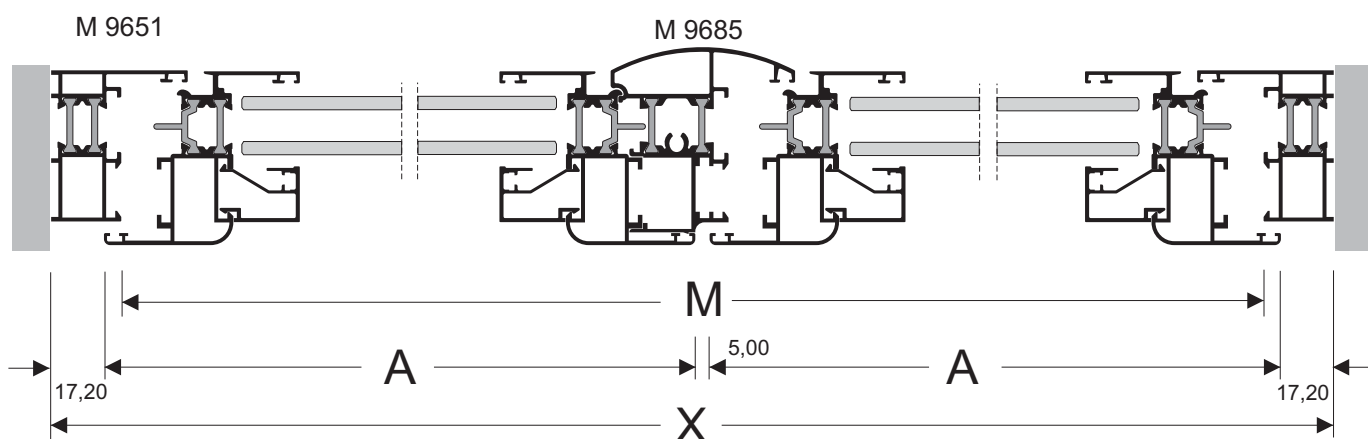

ŠIRINA KRILA  
(WIDTH OF SASH)  $A = \frac{X - 39,4}{2}$  mm ili (or)  $A = \frac{M + 7}{2}$  mm

VISINA KRILA  
(HEIGHT OF SASH)  $A = Y - 34,4\text{ mm}$  ili (or)  $A = M + 12\text{ mm}$

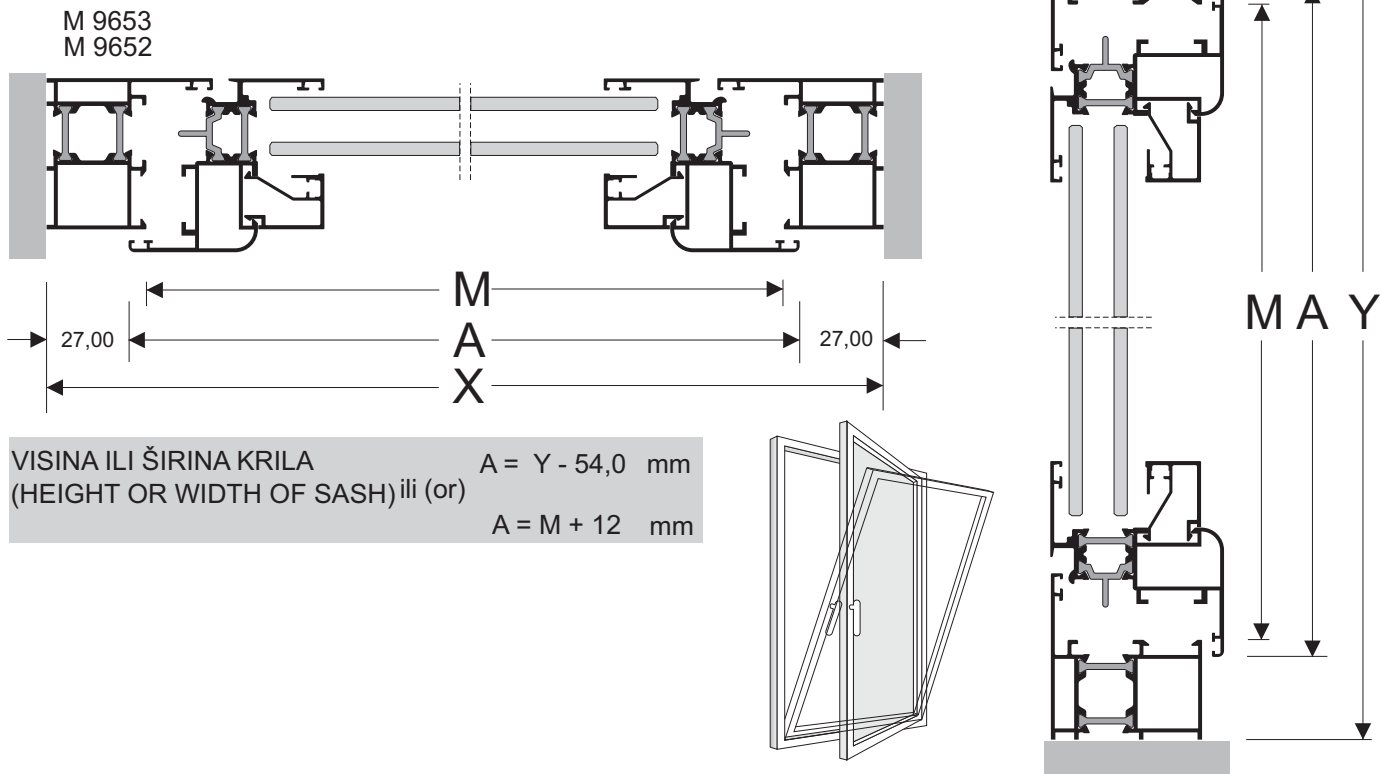
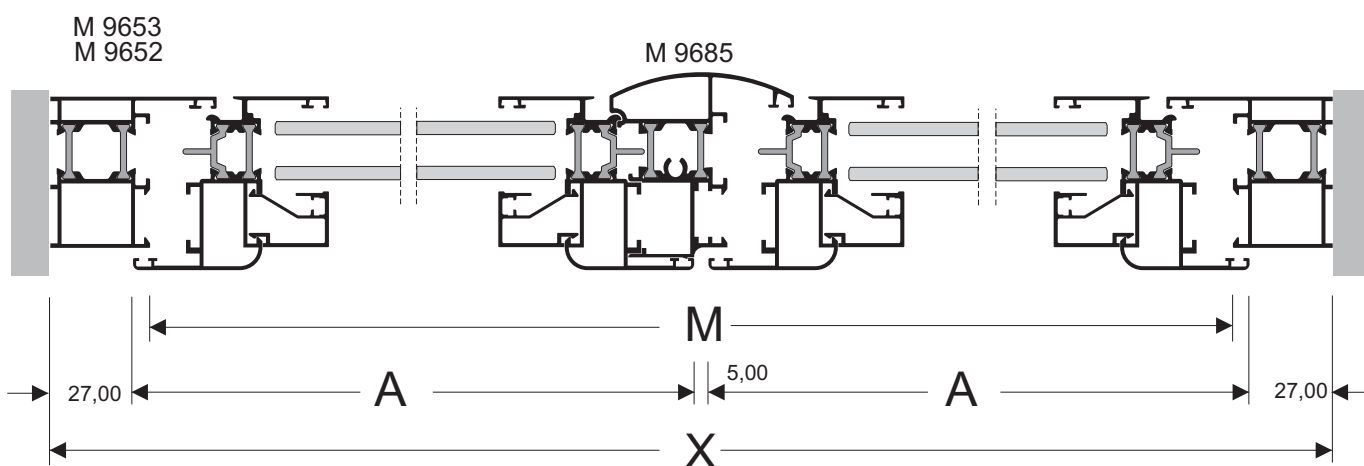
**JEDNORILNI PROZOR/ OKRETNO-NAGIBNI**  
**SINGLE LEAF CASEMENT/ TILT-N-TURN WINDOW**

**DVOKRILNI PROZOR/ OKRETNO-NAGIBNI**  
**DOUBLE LEAF CASEMENT/ TILT-N-TURN WINDOW**

ŠIRINA KRILA  
(WIDTH OF SASH)

$A = \frac{X - 59}{2} \text{ mm}$  ili (or)  $A = \frac{M + 7}{2} \text{ mm}$

VISINA KRILA  
(HEIGHT OF SASH)

$A = Y - 54 \text{ mm}$  ili (or)  $A = M + 12 \text{ mm}$

VRATA  
DOOR

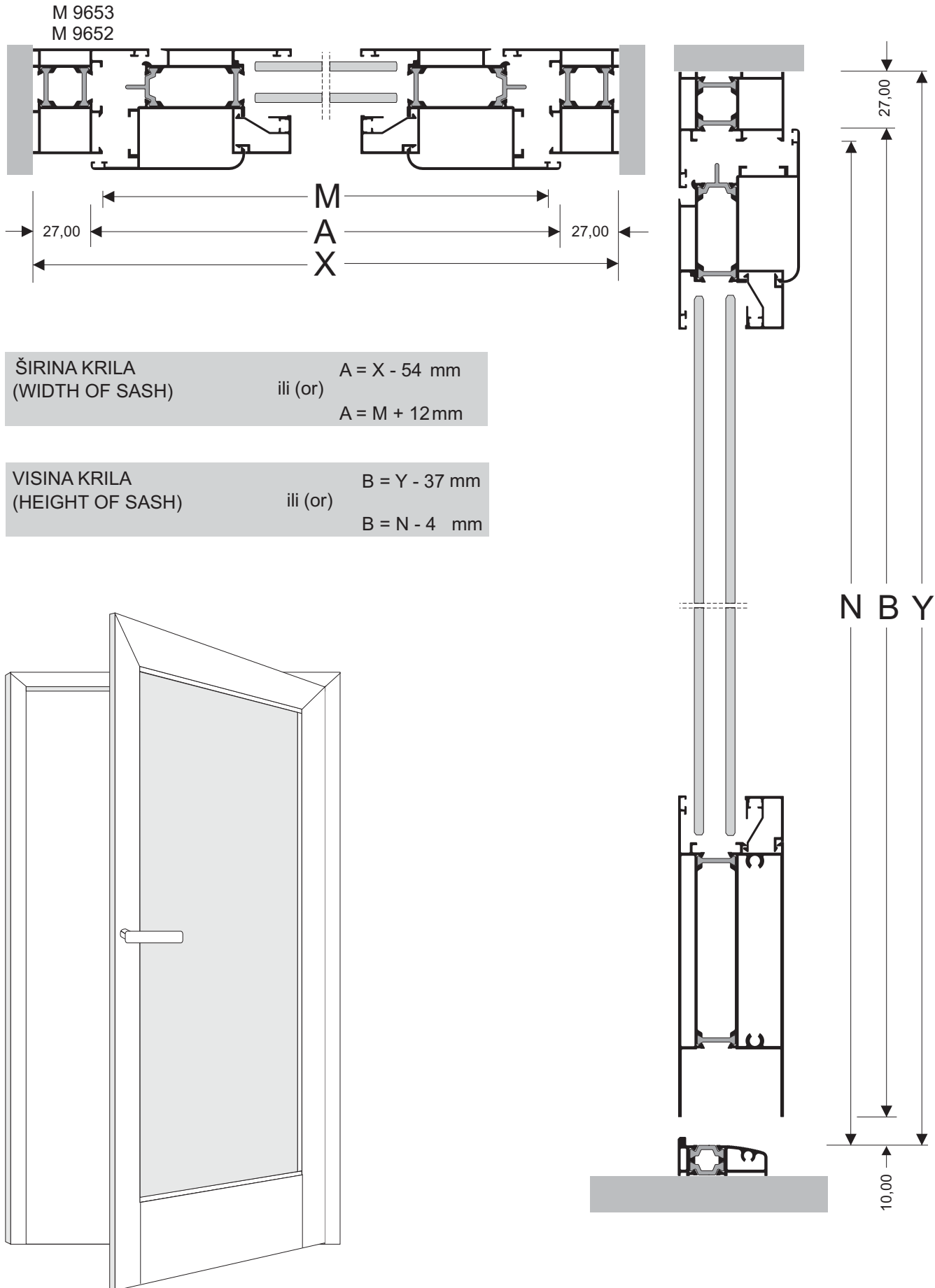

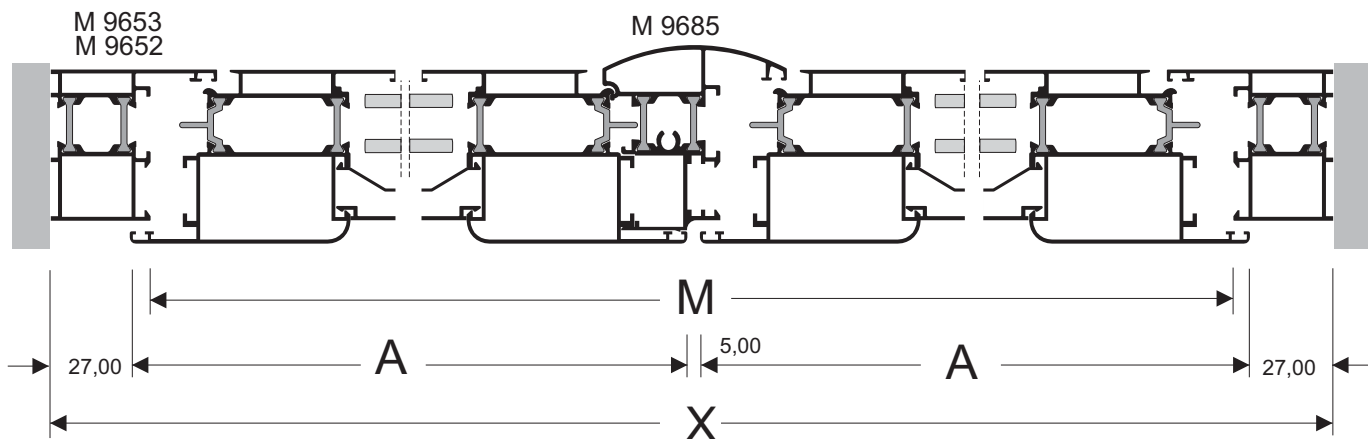
DVOKRILNA VRATA  
 DOUBLE DOOR





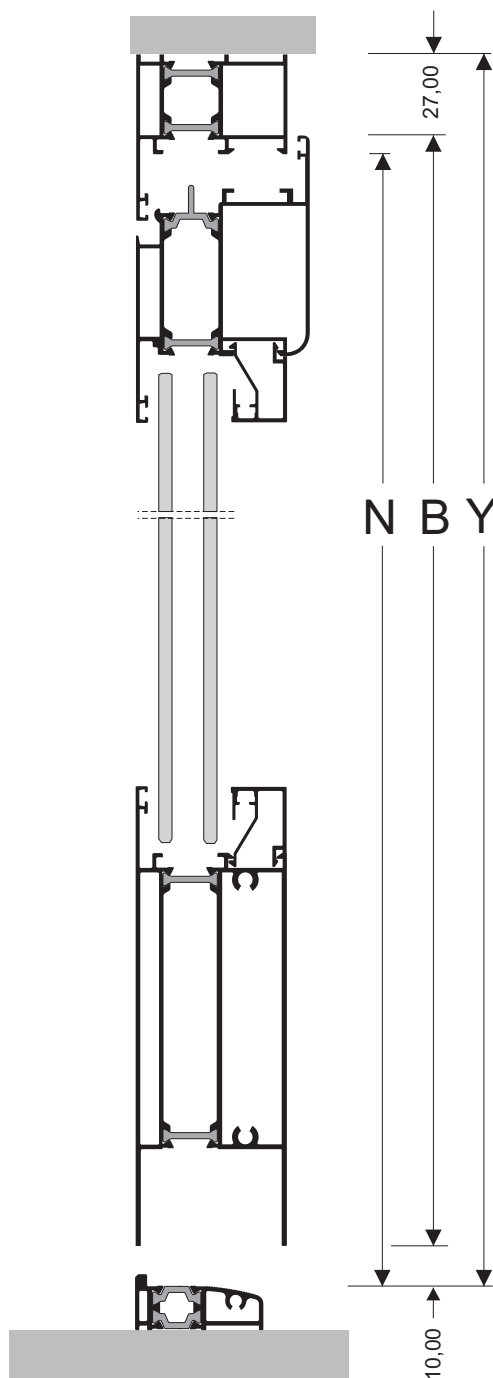
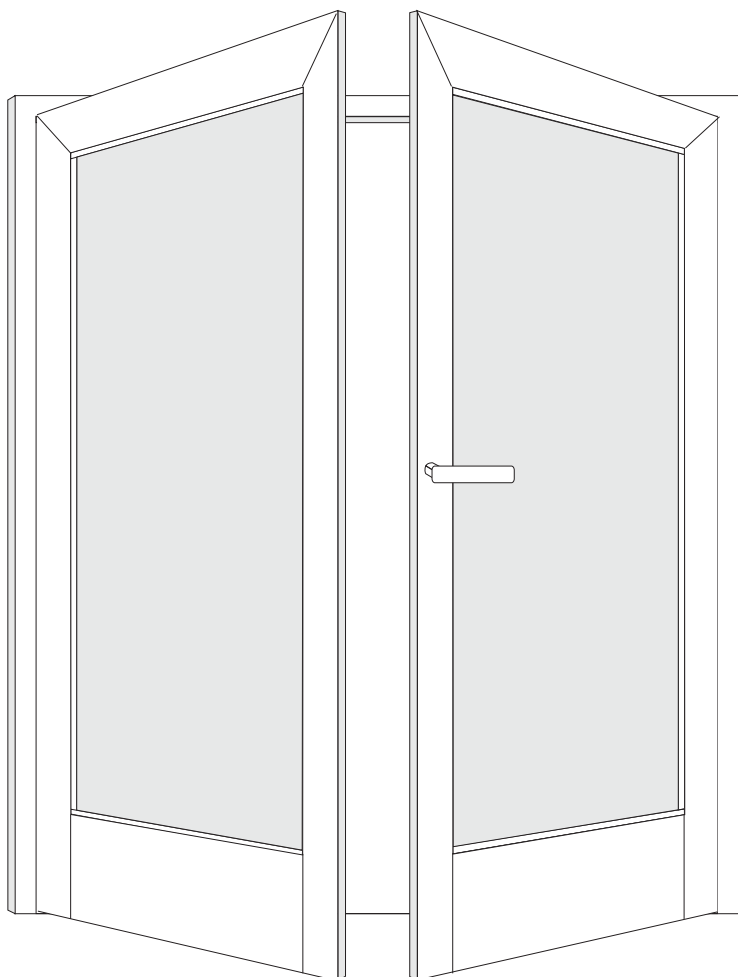



ŠIRINA KRILA  
(WIDTH OF SASH)  $A = \frac{X - 59}{2}$  mm ili (or)  $A = \frac{M + 7}{2}$  mm

VISINA KRILA  
(HEIGHT OF SASH) ili (or)  $B = Y - 37$  mm  
 $B = N - 4$  mm

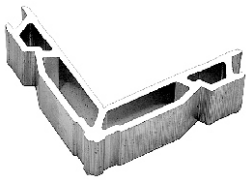

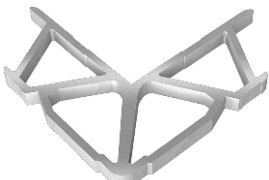
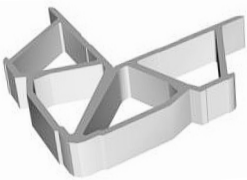









# Pribori i okovi Accessories







<p>110-09-061-00</p> 	<p>KAT. BR. : 110-09-061-00 ART No : 113-09-061-00</p> <p>Stock No :</p> <p>OPIS : KRUTA UGAONA VEZA DESCRIPTION PRESS CORNER</p> <p>MATERIJAL / MATERIAL ALUMINIJUM / ALUMINIUM</p> <p>KAT.BR. : ART No :</p> <p>BOJA : SIROVO COLOR : MILL FINISH</p> <p>PAKOVANJE : PACKAGE :</p> <p>DIMENZIJE : DIMENSION :</p>
<p>115-13-***-**</p> 	<p>KAT.BR.:115-13-***-** ART No :113-13-***-**</p> <p>Stock No :</p> <p>OPIS : KRUTA UGAONA VEZA DESCRIPTION PRESS CORNER</p> <p>MATERIJAL / MATERIAL ALUMINIJUM / ALUMINIUM</p> <p>KAT.BR. : 11*-13-058-00, 11*-13-196-00, ART No : 11*-13-270-00</p> <p>BOJA : SIROVO COLOR : MILL FINISH</p> <p>PAKOVANJE : PACKAGE :</p> <p>DIMENZIJE : DIMENSION :</p>
<p>115-23-***-**</p> 	<p>KAT.BR. 115-23-***-** ART No :113-23-***-**</p> <p>Stock No :</p> <p>OPIS : KRUTA UGAONA VEZA DESCRIPTION PRESS CORNER</p> <p>MATERIJAL / MATERIAL ALUMINIJUM / ALUMINIUM</p> <p>KAT.BR. : 11*-23-058-00, 11*-23-156-00, ART No : 11*-23-196-00, 11*-23-270-00</p> <p>BOJA : SIROVO COLOR : MILL FINISH</p> <p>PAKOVANJE : PACKAGE :</p> <p>DIMENZIJE : DIMENSION :</p>
<p>115-29-***-**</p> 	<p>KAT.BR. 115-29-***-** ART No :113-29-***-**</p> <p>Stock No :</p> <p>OPIS : KRUTA UGAONA VEZA DESCRIPTION PRESS CORNER</p> <p>MATERIJAL / MATERIAL ALUMINIJUM / ALUMINIUM</p> <p>KAT.BR. : 11*-29-061-00, 11*-29-075-00 ART No :</p> <p>BOJA : SIROVO COLOR : MILL FINISH</p> <p>PAKOVANJE : PACKAGE :</p> <p>DIMENZIJE : DIMENSION :</p>
<p>115-33-***-**</p> 	<p>KAT.BR. 115-33-***-** ART No :113-33-***-**</p> <p>Stock No :</p> <p>OPIS : KRUTA UGAONA VEZA DESCRIPTION PRESS CORNER</p> <p>MATERIJAL / MATERIAL ALUMINIJUM / ALUMINIUM</p> <p>KAT.BR. : 11*-33-270-00, 11*-33-056-00, ART No : 11*-33-196-00</p> <p>BOJA : SIROVO COLOR : MILL FINISH</p> <p>PAKOVANJE : PACKAGE :</p> <p>DOMENZIJE : DIMENSION :</p>
<p>115-43-270-00</p> 	<p>KAT.BR. 115-43-270-00 ART No :113-43-270-00</p> <p>Stock No :</p> <p>OPIS : KRUTA UGAONA VEZA DESCRIPTION PRESS CORNER</p> <p>MATERIJAL / MATERIAL ALUMINIJUM / ALUMINIUM</p> <p>KAT.BR. : ART No :</p> <p>BOJA : SIROVO COLOR : MILL FINISH</p> <p>PAKOVANJE : PACKAGE :</p> <p>DIMENZIJE : DIMENSION :</p>
<p>3520</p> 	<p>KAT.BR. 3520 ART No :3520</p> <p>Stock No :</p> <p>OPIS : RASTAVLJIVA VEZA DESCRIPTION SCREW CORNER</p> <p>MATERIJAL / MATERIAL ALUMINIJUM / ALUMINIUM</p> <p>KAT.BR. : ART No :</p> <p>BOJA : SIROVO COLOR : MILL FINISH</p> <p>PAKOVANJE : PACKAGE :</p> <p>DIMENZIJE :12.8x19.2 DIMENSION :</p>
<p>2633</p> 	<p>KAT.BR. 2633 ART No :2633</p> <p>Stock No :</p> <p>OPIS : RASTAVLJIVA VEZA DESCRIPTION SCREW CORNER</p> <p>MATERIJAL / MATERIAL ALUMINIJUM / ALUMINIUM</p> <p>KAT.BR. : ART No :</p> <p>BOJA : SIROVO COLOR : MILL FINISH</p> <p>PAKOVANJE : PACKAGE :</p> <p>DIMENZIJE :12.8x26.4 DIMENSION :</p>

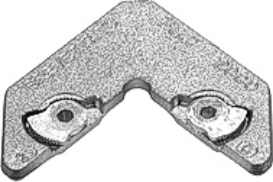

<p>2730</p> 	<p><b>KAT.BR. ART No 2730</b> Stock No :</p> <p>OPIS : RASTAVLJIVA VEZA DESCRIPTION SCREW CORNER</p> <p>MATERIJAL / MATERIAL : ALUMINIJUM / ALUMINIUM</p> <p>KAT.BR. : ART No :</p> <p>BOJA : SIROVO COLOR : MILL FINISH</p> <p>PAKOVANJE : PACKAGE :</p> <p>DIMENZIJE 22.6x26.4 DIMENSION :</p>
<p>2632</p> 	<p><b>KAT.BR. ART No 2632</b> Stock No :</p> <p>OPIS : RASTAVLJIVA VEZA DESCRIPTION SCREW CORNER</p> <p>MATERIJAL / MATERIAL : ALUMINIJUM / ALUMINIUM</p> <p>KAT.BR. : ART No :</p> <p>BOJA : SIROVO COLOR : MILL FINISH</p> <p>PAKOVANJE : PACKAGE :</p> <p>DIMENZIJE 22.6x19.2 DIMENSION :</p>
<p>3522</p> 	<p><b>KAT.BR. ART No 3522</b> Stock No :</p> <p>OPIS : RASTAVLJIVA VEZA DESCRIPTION SCREW CORNER</p> <p>MATERIJAL / MATERIAL : ALUMINIJUM / ALUMINIUM</p> <p>KAT.BR. : ART No :</p> <p>BOJA : SIROVO COLOR : MILL FINISH</p> <p>PAKOVANJE : PACKAGE :</p> <p>DIMENZIJE 32.7x19.2 DIMENSION :</p>
<p>2742</p> 	<p><b>KAT.BR. ART No 2742</b> Stock No :</p> <p>OPIS : RASTAVLJIVA VEZA DESCRIPTION SCREW CORNER</p> <p>MATERIJAL / MATERIAL : ALUMINIJUM / ALUMINIUM</p> <p>KAT.BR. : ART No :</p> <p>BOJA : SIROVO COLOR : MILL FINISH</p> <p>PAKOVANJE : PACKAGE :</p> <p>DIMENZIJE 42.9x26.4 DIMENSION :</p>
<p>2741</p> 	<p><b>KAT.BR. ART No 2741</b> Stock No :</p> <p>OPIS : RASTAVLJIVA VEZA DESCRIPTION SCREW CORNER</p> <p>MATERIJAL / MATERIAL : ALUMINIJUM / ALUMINIUM</p> <p>KAT.BR. : ART No :</p> <p>BOJA : SIROVO COLOR : MILL FINISH</p> <p>PAKOVANJE : PACKAGE :</p> <p>DIMENZIJE 32.7x26.4 DIMENSION :</p>
<p>160-11-***-**</p> 	<p><b>KAT.BR. ART No 160-11-***-**</b> Stock No :</p> <p>OPIS : VEZA ZA "T" PREČKU DESCRIPTION T - CONNECTOR</p> <p>MATERIJAL / MATERIAL : ALUMINIJUM / ALUMINIUM</p> <p>KAT.BR. : 160-11-223-00, 160-11-233-00, ART No : 160-11-213-00</p> <p>BOJA : SIROVO COLOR : MILL FINISH</p> <p>PAKOVANJE : PACKAGE :</p> <p>DIMENZIJE : DIMENSION :</p>
<p>470-11-835-00</p> 	<p><b>KAT.BR. ART No 470-11-835-00</b> Stock No :</p> <p>OPIS : KLIN ZA "T" PREČKU Ø 6 DESCRIPTION : BREAK AWAY NAIL FOR T -PROFILE</p> <p>MATERIJAL / MATERIAL : ČELIK / STEEL</p> <p>KAT.BR. : ART No :</p> <p>BOJA : COLOR :</p> <p>PAKOVANJE : PACKAGE :</p> <p>DIMENZIJE : DIMENSION :</p>
<p>165-20-230-00</p> 	<p><b>KAT.BR. ART No 165-20-230-00</b> Stock No :</p> <p>OPIS : LIVENA SPOJNICA ZA T PREČKU DESCRIPTION "T" CONNECTOR</p> <p>MATERIJAL / MATERIAL : LIVENI AL / CAST ALUMINIUM</p> <p>KAT.BR. : ART No :</p> <p>BOJA : SIROVO COLOR : MILL FINISH</p> <p>PAKOVANJE : PACKAGE :</p> <p>DIMENZIJE : DIMENSION :</p>

<p>165-20-330-00</p> 	<p><b>KAT.BR. :</b> <b>ART No :</b> <b>165-20-330-00</b> Stock No :</p> <p><b>OPIS :</b> LIVENA SPOJINCA ZA T PREČKU <b>DESCRIPTION :</b> "T" CONNECTOR</p> <p><b>MATERIJAL / MATERIAL :</b> LIVENI AL / CAST ALUMINIUM</p> <p><b>KAT.BR. :</b> <b>ART No :</b></p> <p><b>BOJA :</b> SIROVO <b>COLOR :</b> MILL FINISH</p> <p><b>PAKOVANJE :</b> <b>PACKAGE :</b></p> <p><b>DIMENZIJE :</b> <b>DIMENSION :</b></p>
<p>165-00-001-00</p> 	<p><b>KAT.BR. :</b> <b>ART No :</b> <b>165-00-001-00</b> Stock No :</p> <p><b>OPIS :</b> ŠABLON <b>DESCRIPTION :</b> DRILLING GUIDE</p> <p><b>MATERIJAL / MATERIAL :</b> LIVENI AL / CAST ALUMINIUM</p> <p><b>KAT.BR. :</b> <b>ART No :</b></p> <p><b>BOJA :</b> SIROVO <b>COLOR :</b> MILL FINISH</p> <p><b>PAKOVANJE :</b> <b>PACKAGE :</b></p> <p><b>DIMENZIJE :</b> <b>DIMENSION :</b></p>
<p>165-11-002-00</p> 	<p><b>KAT.BR. :</b> <b>ART No :</b> <b>165-96-502-00</b> Stock No :</p> <p><b>OPIS :</b> DODATNA VEZA T PRECKE(lijeva) <b>DESCRIPTION :</b> ALIGNMENT CORNER</p> <p><b>MATERIJAL / MATERIAL :</b> LIVENI AL / CAST ALUMINIUM</p> <p><b>KAT.BR. :</b> <b>ART No :</b></p> <p><b>BOJA :</b> SIROVO <b>COLOR :</b> MILL FINISH</p> <p><b>PAKOVANJE :</b> <b>PACKAGE :</b></p> <p><b>DIMENZIJE :</b> <b>DIMENSION :</b></p>
<p>165-11-001-00</p> 	<p><b>KAT.BR. :</b> <b>ART No :</b> <b>165-96-501-00</b> Stock No :</p> <p><b>OPIS :</b> DODATNA VEZA T PRECKE(desna) <b>DESCRIPTION :</b> ALIGNMENT CORNER</p> <p><b>MATERIJAL / MATERIAL :</b> LIVENI AL / CAST ALUMINIUM</p> <p><b>KAT.BR. :</b> <b>ART No :</b></p> <p><b>BOJA :</b> SIROVO <b>COLOR :</b> MILL FINISH</p> <p><b>PAKOVANJE :</b> <b>PACKAGE :</b></p> <p><b>DIMENZIJE :</b> <b>DIMENSION :</b></p>
<p>310-11-501-00</p> 	<p><b>KAT.BR. :</b> <b>ART No :</b> <b>310-11-501-00</b> Stock No :</p> <p><b>OPIS :</b> ČEP ZA TEHNOLOSKI OTVOR <b>DESCRIPTION :</b> WATER CAP</p> <p><b>MATERIJAL / MATERIAL :</b> POLIAMID / POLYAMIDE</p> <p><b>KAT.BR. :</b> <b>ART No :</b></p> <p><b>BOJA :</b> CRNA/BIJELA <b>COLOR :</b> BLACK/WHITE</p> <p><b>PAKOVANJE :</b> <b>PACKAGE :</b></p> <p><b>DIMENZIJE :</b> <b>DIMENSION :</b></p>
<p>300-09-665-00</p> 	<p><b>KAT.BR. :</b> <b>ART No :</b> <b>300-09-665-00</b> Stock No :</p> <p><b>OPIS :</b> ČEP ZA SREDNJU PREČKU <b>DESCRIPTION :</b> END COVER</p> <p><b>MATERIJAL / MATERIAL :</b> POLIAMID / POLYAMIDE</p> <p><b>PROFIL :</b> M9665 <b>PROFILE :</b></p> <p><b>BOJA :</b> CRNA <b>COLOR :</b> BLACK</p> <p><b>PAKOVANJE :</b> <b>PACKAGE :</b></p> <p><b>DIMENZIJE :</b> <b>DIMENSION :</b></p>
<p>300-09-685-00</p> 	<p><b>KAT.BR. :</b> <b>ART No :</b> <b>300-09-685-00</b> Stock No :</p> <p><b>OPIS :</b> ČEP ZA SREDNJU PREČKU <b>DESCRIPTION :</b> END COVER</p> <p><b>MATERIJAL / MATERIAL :</b> POLIAMID / POLYAMIDE</p> <p><b>PROFIL :</b> M9685 <b>PROFILE :</b></p> <p><b>BOJA :</b> CRNA <b>COLOR :</b> BLACK</p> <p><b>PAKOVANJE :</b> <b>PACKAGE :</b></p> <p><b>DIMENZIJE :</b> <b>DIMENSION :</b></p>
<p>310-09-681-00</p> 	<p><b>KAT.BR. :</b> <b>ART No :</b> <b>310-09-681-00</b> Stock No :</p> <p><b>OPIS :</b> ČEP ZA PROFIL M9681 <b>DESCRIPTION :</b> END COVER</p> <p><b>MATERIJAL / MATERIAL :</b> POLIAMID / POLYAMIDE</p> <p><b>PROFIL :</b> M9681 <b>PROFILE :</b></p> <p><b>BOJA :</b> CRNA <b>COLOR :</b> BLACK</p> <p><b>PAKOVANJE :</b> <b>PACKAGE :</b></p> <p><b>DIMENZIJE :</b> <b>DIMENSION :</b></p>

<p>310-09-673-00</p> 	<p>KAT.BR. : 310-09-673-00 ART No. : 310-09-673-00 Stock No :</p> <p>OPIS : ČEP ZA PROFIL M9673 DESCRIPTION : END COVER</p> <p>BOJA : CRNA COLOR : BLACK</p> <p>MATERIJAL / MATERIAL POLIAMID / POLYAMIDE</p> <p>PAKOVANJE : PACKAGE :</p> <p>PROFIL : M 9673 PROFILE :</p> <p>DIMENZIJE : DIMENSION :</p>
<p>310-11-210-00</p> 	<p>KAT.BR. : 310-11-210-00 ART No. : 310-11-210-00 Stock No :</p> <p>OPIS : ČEP ZA PROFIL M11210 DESCRIPTION : END COVER</p> <p>BOJA : CRNA COLOR : BLACK</p> <p>MATERIJAL / MATERIAL POLIAMID / POLYAMIDE</p> <p>PAKOVANJE : PACKAGE :</p> <p>PROFIL : M 11210 PROFILE :</p> <p>DIMENZIJE : DIMENSION :</p>
<p>310-11-226-00</p> 	<p>KAT.BR. : 310-11-226-00 ART No. : 310-11-226-00 Stock No :</p> <p>OPIS : ČEP ZA OKAPNICU M11226 DESCRIPTION : END COVER</p> <p>BOJA : CRNA COLOR : BLACK</p> <p>MATERIJAL / MATERIAL POLIAMID / POLYAMIDE</p> <p>PAKOVANJE : PACKAGE :</p> <p>PROFIL : M 11226 PROFILE :</p> <p>DIMENZIJE : DIMENSION :</p>
<p>310-11-116-00</p> 	<p>KAT.BR. : 310-11-116-00 ART No. : 310-11-116-00 Stock No :</p> <p>OPIS : ČEP ZA OKAPNICU M11116 DESCRIPTION : END COVER</p> <p>BOJA : CRNA/BIJELA COLOR : BLACK/WHITE</p> <p>MATERIJAL / MATERIAL POLIAMID / POLYAMIDE</p> <p>PAKOVANJE : PACKAGE :</p> <p>PROFIL : M11116 PROFILE :</p> <p>DIMENZIJE : DIMENSION :</p>
<p>310-09-317-00</p> 	<p>KAT.BR. : 310-09-317-00 ART No. : 310-09-317-00 Stock No :</p> <p>OPIS : ČEP ZA OKAPNICU M9317 DESCRIPTION : END COVER</p> <p>BOJA : CRNA/BIJELA COLOR : BLACK/WHITE</p> <p>MATERIJAL / MATERIAL POLIAMID / POLYAMIDE</p> <p>PAKOVANJE : PACKAGE :</p> <p>PROFIL : M9317 PROFILE :</p> <p>DIMENZIJE : DIMENSION :</p>
<p>310-09-672-00</p> 	<p>KAT.BR. : 310-09-672-00 ART No. : 310-09-672-00 Stock No :</p> <p>OPIS : ČEP ZA PRAG DESCRIPTION : END COVER</p> <p>BOJA : CRNA COLOR : BLACK</p> <p>MATERIJAL / MATERIAL POLIAMID / POLYAMIDE</p> <p>PAKOVANJE : PACKAGE :</p> <p>PROFIL : M 9672 PROFILE :</p> <p>DIMENZIJE : DIMENSION :</p>
<p>180-19-000-00</p> 	<p>KAT.BR. : 180-19-000-00 ART No. : 180-19-000-00 Stock No :</p> <p>OPIS : DODATNA VEZA DESCRIPTION : ALIGNMENT CORNER</p> <p>BOJA : COLOR :</p> <p>MATERIJAL / MATERIAL : ČELIK / STEEL</p> <p>PAKOVANJE : PACKAGE :</p> <p>KAT.BR. : ART No. :</p> <p>DIMENZIJE : DIMENSION :</p>
<p>180-11-118-00</p> 	<p>KAT.BR. : 180-11-118-00 ART No. : 180-11-118-00 Stock No :</p> <p>OPIS : UGLIĆ DESCRIPTION : ALIGNMENT CORNER</p> <p>BOJA : CRNA COLOR : BLACK</p> <p>MATERIJAL / MATERIAL POLIAMID / POLYAMIDE</p> <p>PAKOVANJE : PACKAGE :</p> <p>KAT.BR. : ART No. :</p> <p>DIMENZIJE : DIMENSION :</p>

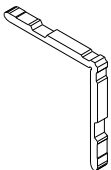
<p>180-20-010-00</p> 	<p>KAT.BR. : 180-20-010-00 ART No : 180-20-010-00 Stock No :</p> <p>OPIS : DODATNA VEZA DESCRIPTION ALIGNMENT CORNER</p> <p>BOJA : CRNA COLOR : BLACK</p> <p>MATERIJAL / MATERIAL POLIAMID / POLYAMIDE</p> <p>PAKOVANJE : PACKAGE :</p> <p>KAT.BR. : ART No :</p> <p>DIMENZIJE : DIMENSION :</p>
<p>180-20-030-00</p> 	<p>KAT.BR. : 180-20-030-00 ART No : 180-20-030-00 Stock No :</p> <p>OPIS : DODATNA VEZA DESCRIPTION ALIGNMENT CORNER</p> <p>BOJA : SIROVO COLOR : MILL FINISH</p> <p>MATERIJAL / MATERIAL LIVENI AL / CAST ALUMINIUM</p> <p>PAKOVANJE : PACKAGE :</p> <p>KAT.BR. : ART No :</p> <p>DIMENZIJE : DIMENSION :</p>
<p>170-60-561-00</p> 	<p>KAT.BR. : 170-60-561-00 ART No : 170-60-561-00 Stock No :</p> <p>OPIS : UGAO ZA LAJSNU M11461 DESCRIPTION CORNER PIECE FOR GLAZING BEAD</p> <p>BOJA : SIROVO COLOR : MILL FINISH</p> <p>MATERIJAL / MATERIAL : LIVENI AL / DIE CAST</p> <p>PAKOVANJE : PACKAGE :</p> <p>KAT.BR. : 170-60-561-02 BIJELA-WHITE, ART No : 170-60-561-03 CRNA - BLACK</p> <p>DIMENZIJE : DIMENSION :</p>
<p>170-60-562-00</p> 	<p>KAT.BR. : 170-60-562-00 ART No : 170-60-562-00 Stock No :</p> <p>OPIS : UGAO ZA LAJSNU M11462 DESCRIPTION CORNER PIECE FOR GLAZING BEAD</p> <p>BOJA : SIROVO COLOR : MILL FINISH</p> <p>MATERIJAL / MATERIAL : LIVENI AL / DIE CAST</p> <p>PAKOVANJE : PACKAGE :</p> <p>KAT.BR. : 170-60-562-02 BIJELA-WHITE, ART No : 170-60-562-03 CRNA - BLACK</p> <p>DIMENZIJE : DIMENSION :</p>
<p>170-60-563-00</p> 	<p>KAT.BR. : 170-60-563-00 ART No : 170-60-563-00 Stock No :</p> <p>OPIS : UGAO ZA LAJSNU M11463 DESCRIPTION CORNER PIECE FOR GLAZING BEAD</p> <p>BOJA : SIROVO COLOR : MILL FINISH</p> <p>MATERIJAL / MATERIAL : LIVENI AL / DIE CAST</p> <p>PAKOVANJE : PACKAGE :</p> <p>KAT.BR. : 170-60-563-02 BIJELA-WHITE, ART No : 170-60-563-03 CRNA - BLACK</p> <p>DIMENZIJE : DIMENSION :</p>
<p>170-60-564-00</p> 	<p>KAT.BR. : 170-60-564-00 ART No : 170-60-564-00 Stock No :</p> <p>OPIS : UGAO ZA LAJSNU M11464 DESCRIPTION CORNER PIECE FOR GLAZING BEAD</p> <p>BOJA : SIROVO COLOR : MILL FINISH</p> <p>MATERIJAL / MATERIAL : LIVENI AL / DIE CAST</p> <p>PAKOVANJE : PACKAGE :</p> <p>KAT.BR. : 170-60-564-02 BIJELA-WHITE, ART No : 170-60-564-03 CRNA - BLACK</p> <p>DIMENZIJE : DIMENSION :</p>
<p>45802.***</p> 	<p>KAT.BR. : 45802.*** ART No : 45802.*** Stock No :</p> <p>OPIS : KONEKTOR ZA T-PREČKU DESCRIPTION T-CONNECTOR</p> <p>BOJA : SIROVO COLOR : MILL FINISH</p> <p>MATERIJAL / MATERIAL : ALUMINIJUM / ALUMINIUM</p> <p>PAKOVANJE : PACKAGE :</p> <p>KAT.BR. : 45802.223 PROFIL/PROFILE M9659 ART No : 45802.233 PROFIL/PROFILE M9690</p> <p>DIMENZIJE : DIMENSION :</p>
<p>110-05-059-00</p> 	<p>KAT.BR. : 110-05-059-00 ART No : 113-05-059-00 Stock No :</p> <p>OPIS : KRUTA SPOJNICA DESCRIPTION PRESS CORNER</p> <p>BOJA : SIROVO COLOR : MILL FINISH</p> <p>MATERIJAL / MATERIAL : ALUMINIJUM / ALUMINIUM</p> <p>PAKOVANJE : PACKAGE :</p> <p>KAT.BR. : ART No :</p> <p>DIMENZIJE : DIMENSION :</p>

113-11-283-00

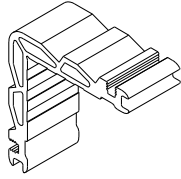

KAT.BR. :  
ART No : **113-11-283-00**

Stock No :

OPIS : KRUTA SPOJNICA  
DESCRIPTION PRESS CORNER

BOJA : SIROVO  
COLOR : MILL FINISH

MATERIJAL / MATERIAL ALUMINIJUM/ALUMINIUM

PAKOVANJE :  
PACKAGE :

KAT.BR. :  
ART No :

DIMENZIJE :  
DIMENSION :

180-20-040-00

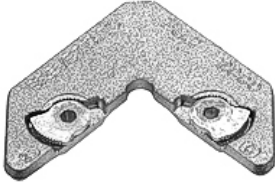

KAT.BR. :  
ART No : **180-20-040-00**

Stock No :

OPIS : DODATNA VEZA  
DESCRIPTION ALIGNMENT CORNER

BOJA : SIROVO  
COLOR : MILL FINISH

MATERIJAL / MATERIAL LIVENI AL / CAST ALUMINIUM

PAKOVANJE :  
PACKAGE :

KAT.BR. :  
ART No :

DIMENZIJE :  
DIMENSION :

180-20-025-00



KAT.BR. :  
ART No : **180-20-025-00**

Stock No :

OPIS : DODATNA SPOJNICA  
DESCRIPTION ALIGNMENT CORNER









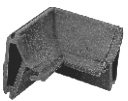

BOJA : CRNO  
COLOR : BLACK

MATERIJAL / MATERIAL : POLIAMID / POLYAMIDE

PAKOVANJE :  
PACKAGE :

KAT.BR. :  
ART No :

DIMENZIJE :  
DIMENSION :

	<p>KAT.BR. ART No: <b>200-96-500-01</b> Stock No : _____</p> <p>OPIS / DESCRIPTION : CENTRALNA ZAPTIVKA / CENTRAL GASKET</p> <p>MATERIJAL / MATERIAL : EPDM PLUS BOJA / COLOR: CRNA / BLACK</p>
	<p>KAT.BR. ART No: <b>255-96-500-00</b> Stock No : _____</p> <p>OPIS / DESCRIPTION : COŠAK / VULCANIZED CORNER</p> <p>MATERIJAL / MATERIAL : EPDM BOJA / COLOR: CRNA / BLACK</p>
	<p>KAT.BR. ART No: <b>255-96-500-01</b> Stock No : _____</p> <p>OPIS / DESCRIPTION : ČOŠAK / VULCANIZED CORNER</p> <p>MATERIJAL / MATERIAL : EPDM BOJA / COLOR: CRNA / BLACK</p>
	<p>KAT.BR. ART No: <b>220-11-001-00</b> Stock No : _____</p> <p>OPIS / DESCRIPTION : ZAPTIVKA / GASKET</p> <p>MATERIJAL / MATERIAL : EPDM BOJA / COLOR: CRNA / BLACK</p>
	<p>KAT.BR. ART No: <b>220-11-002-00</b> Stock No : _____</p> <p>OPIS / DESCRIPTION : ZAPTIVKA / GASKET</p> <p>MATERIJAL / MATERIAL : EPDM BOJA / COLOR: CRNA / BLACK</p>
	<p>KAT.BR. ART No: <b>250-11-226-00</b> Stock No : _____</p> <p>OPIS / DESCRIPTION : ZAPTIVKA / GASKET</p> <p>MATERIJAL / MATERIAL : EPDM BOJA / COLOR: CRNA / BLACK</p>
	<p>KAT.BR. ART No: <b>250-11-170-00</b> Stock No : _____</p> <p>OPIS / DESCRIPTION : ZAPTIVKA / GASKET</p> <p>MATERIJAL / MATERIAL : EPDM BOJA / COLOR: CRNA / BLACK</p>
	<p>KAT.BR. ART No: <b>250-11-270-00</b> Stock No : _____</p> <p>OPIS / DESCRIPTION : ZAPTIVKA / GASKET</p> <p>MATERIJAL / MATERIAL : EPDM BOJA / COLOR: CRNA / BLACK</p>
	<p>KAT.BR. ART No: <b>200-05-304-00</b> Stock No : _____</p> <p>OPIS / DESCRIPTION : ZAPTIVKA ZA STAKLO 3-4 mm / GLAZING GASKET 3-4 mm</p> <p>MATERIJAL / MATERIAL : EPDM BOJA / COLOR: CRNA / BLACK</p>
	<p>KAT.BR. ART No: <b>200-06-860-00</b> Stock No : _____</p> <p>OPIS / DESCRIPTION : ZAPTIVKA ZA STAKLO 4 mm / GLAZING GASKET 4 mm</p> <p>MATERIJAL / MATERIAL : EPDM BOJA / COLOR: CRNA / BLACK</p>
	<p>KAT.BR. ART No: <b>210-96-500-00</b> Stock No : _____</p> <p>OPIS / DESCRIPTION : CENTRALNA ZAPTIVKA / CENTRAL GASKET</p> <p>MATERIJAL / MATERIAL : EPDM PLUS BOJA / COLOR: CRNA / BLACK</p>





- Telefoni: ++387 56 733 750; 710 571; 710-690
- Fax: ++387 56 733 196; 710 681
- E-mail: [bhaluminium@alpro-vl.com](mailto:bhaluminium@alpro-vl.com)
- Web: [www.alumil.com](http://www.alumil.com), [www.alumil.ba](http://www.alumil.ba), [www.alpro-vl.com](http://www.alpro-vl.com)